

Rs.10/-



# Science Horizon



ODISHA BIGYAN ACADEMY  
PUBLICATION

Volume 10

Issue 5

May 2025



**REQUEST TO ESTEEMED LIFE MEMBERS / PATRONS OF  
ODISHA BIGYAN ACADEMY TO PROVIDE ACTIVE  
E-MAIL ID, COMPLETE POSTAL ADDRESS & MOBILE NUMBER**

It has come to our knowledge that the e-mail sent by Odisha Bigyan Academy are not delivered to some esteemed members due to inactive e-mail id, which are not in operation. The members not receiving e-mails from Odisha Bigyan Academy are requested to provide their active e-mail id, complete postal address and mobile number to Odisha Bigyan Academy through e-mail id : odishabigyanacademy1@gmail.com at the earliest.

*Secretary  
Odisha Bigyan Academy*

**FEEDBACK**

**Dear Mayadhar Babu,**

I studied the editorial written by you in the April, 2025 issue of SH. It is timely. It is very well written summarizing latest technological manifestations of quantum theory. Congratulations for the same. I fail to understand why our scholars are in so supine state when world is buzzing in the age of quantum theory and relativity.

*Balaram Sahoo  
Former Professor of Chemistry, IIT Kharagpur*



# SCIENCE HORIZON

Volume - 10

May-2025

Issue - 5

## President

Prof. Bibhuti Bhusan Mishra  
Odisha Bigyan Academy

## Managing Editor

Prof. Ashis Kumar Mohanty  
Secretary  
Odisha Bigyan Academy

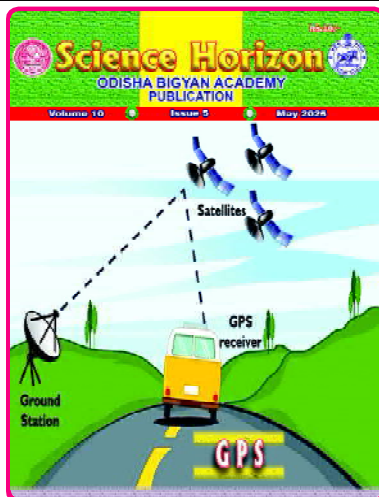

## Editor

Er. Mayadhar Swain  
Former Director,  
School of Electrical Engineering,  
KIIT University, Bhubaneswar  
Mob.: 9438693724  
E-mail: mayadhar2002@yahoo.co.in

## Language Expert

Prof. Sachidananda Tripathy

## DTP & Cover Design

Kalakar Sahoo

## EDITORIAL BOARD

### 1. Prof. Niranjan Barik

Former Professor and Head, Department of Physics,  
Utkal University, Vani Vihar, Bhubaneswar  
BARYON, HIG-193 (K5), Kalinga Vihar, Po. Patrapada,  
Bhubaneswar-751019, Mob. 9437010478,  
E-mail: dr.nbarik@gmail.com

### 2. Prof. Ramesh Chandra Parida

Former Professor of Chemistry, Basic Science College,  
Odisha University of Agriculture and Technology,  
Bhubaneswar  
Plot No. 124/2445, Khandagiri Vihar, Bhubaneswar-30,  
Mob. 9937985767, E-mail: paridanana47@gmail.com

### 3. Dr. Choudhury Satyabrata Nanda

Former Internal Medicine Specialist at District  
Headquarters Hospital, Balasore

At./Po. Gopal Gaon, Town High School Road, Balasore-  
756001, Mob. 9040832663,  
E-mail: babunanda52@gmail.com

### 4. Dr. Rajballav Mohanty

Former Head, Department of Botany, Dhenkanal (Auto.)  
College, Dhenkanal  
Plot No. 1311/7628, At. Satyavihar (Pandra),  
Po. Rasulgarh, Bhubaneswar-751010  
Mob. 9439699317, E-mail: rajballavmohanty@gmail.com

### 5. Dr. Nilambar Biswal

Former HOD, Department of Mathematics, Banki (Auto.)  
College, Banki, Cuttack  
A/101, Bishal Residency, Sriram Nagar, Old Town,  
Bhubaneswar-751002, Mob. 9937948664,  
E-mail: nilambarbiswal8@gmail.com

## About the Publication

Description	: Magazine
Starting Year of Publication	: 2011 without RNI Registration & 2016 with RNI Registration
Frequency	: Monthly
Subject	: Science based articles
Language	: English
Aims & Scope	: Popularisation of Science among school and college students and the general public

❧ **CONTENTS** ❧

Subject	Author	Page
1. Editorial : Polluted Cities	◆ Er. Mayadhar Swain	195
2. Story of The Electron (Part-17)	◆ Balaram Sahoo Prafulla Kumar Pujapanda	197
3. Atoms to Humanity	◆ Dr. Bibhuti Narayan Biswal	201
4. The Science Behind GPS	◆ Dr. (Mrs.) Mridula Mishra	203
5. Logarithmic Function	◆ Satyabrata Rout	207
6. Photosynthesizing Animal Cell Created	◆ Dr. Ramesh Chandra Parida Dr. Sachidananda Muni	210
7. Invaluable Camphor Tree	◆ Dr. Rajballav Mohanty Dr. Taranisen Panda	213
8. Multifarious Benefits of Amazing Plant Bamboo	◆ Dr. Sadasiva Biswal	216
9. Preserving the Olive Ridley Turtles in Odisha: A Conservation Success Story Unfolds	◆ Subhra Patra	221
10. Zoonotic Importance of Cat Scratch Disease in Human	◆ Akankhya Chakravarty Santwana Palai Kautuk Kumar Sardar	225
11. Wind Energy	◆ Er. Mayadhar Swain	230
12. Mahendragiri: Rationale for A Biosphere Reserve	◆ Dr. Bijay Ketan Patnaik	236
13. Recent News on Science & Technology		239





# Editorial

# 1

## POLLUTED CITIES



Day-by-day the size and population of the cities are increasing throughout the world. With this, the pollution level of the cities is also increasing. The World Air Quality Report 2024 prepared by Swiss Air Quality Technology Company (IQAir) and released in March this year notes the air quality in several cities. PM (Particulate Matter) 2.5 is the key indicator of the air quality. It is a mixture of tiny particles and droplets in the air that are 2.5 micrometers or less in diameter. It may be made up of smoke, soot, dust, ash, pollen and other substances. It is emitted during the combustion of solid and liquid fuels in power generation, domestic heating and vehicle engines. It has adverse effects on health causing respiratory illness, chronic kidney disease, cancer and increasing risk of cardiovascular diseases.

World Health Organisation (WHO) annual guideline for PM 2.5 is 5 micrograms per cubic meter ( $\mu\text{g}/\text{m}^3$ ). It is a very strict guideline and difficult to achieve considering the requirement of power alongwith construction works and vehicles used. Only seven countries meet the WHO guideline for

annual average PM 2.5 level. They are Australia, Bahamas, Barbados, Estonia, Grenada, Iceland and New Zealand. No city in East Asia, South East Asia and West Asia meet the WHO guidelines. As per the report, only 17% of the 8954 cities across the world meet the WHO guideline. Out of the 138 countries and regions, 126 (91.3%) exceeds the WHO annual PM 2.5 guidelines. Central and South Asia are home to the top seven most polluted cities in the world.

While WHO guideline for PM 2.5 is  $5 \mu\text{g}/\text{m}^3$ , Central Pollution Control Board (CPCB) of India has fixed it at  $40 \mu\text{g}/\text{m}^3$ . As per the report, world's 20 most polluted cities are in India with Byrnihat in Meghalaya topping the chart with an annual average PM2.5 concentration of  $128.2 \mu\text{g}/\text{m}^3$ . Byrnihat, located at the border of Meghalaya and Assam is an industrial city. The industries include those involved in the production of coke (fuel), cement, ferro alloys and steel and in distillation and brick making. The other cities are Mullanpur (Punjab), Faridabad, Loni, Gurgaon, Ganganagar,

Greater Noida, Bhiwadi, Muzaffarnagar, Hanumangarh, Noida and Delhi. Incidentally, New Delhi is the most polluted capital in the world with average annual PM 2.5 of  $91.8 \mu\text{g}/\text{m}^3$ . The top five polluted capitals are New Delhi, N'Djamena, Dhaka, Kinshasa and Islamabad with annual average PM 2.5 concentration of  $91.8 \mu\text{g}/\text{m}^3$ ,  $91.6 \mu\text{g}/\text{m}^3$ ,  $78 \mu\text{g}/\text{m}^3$ ,  $58.2 \mu\text{g}/\text{m}^3$  and  $52.4 \mu\text{g}/\text{m}^3$  respectively. In fact, between 2018 and 2024, New Delhi has topped the list except in 2022 when N'Djamena edged past it.

The report also states that India is the fifth most polluted country, with an annual average PM 2.5 of  $50.6 \mu\text{g}/\text{m}^3$  which is ten times higher than the WHO guidelines. In 2023, India was the third most polluted country. IQAir has examined data from over 40,000 air quality monitoring stations at 8954 locations in 138 countries. The five most polluted countries according to the report are Chad, Bangladesh, Pakistan, Congo and India with annual average PM 2.5 concentrations of  $91.8 \mu\text{g}/\text{m}^3$ ,  $78 \mu\text{g}/\text{m}^3$ ,  $73.7 \mu\text{g}/\text{m}^3$ ,  $58.2 \mu\text{g}/\text{m}^3$  and  $50.6 \mu\text{g}/\text{m}^3$  respectively.

Another method of measurement of pollution is Air Quality index (AQI) which considers presence of PM 10, carbon monoxide, sulphur dioxide, nitrogen oxide and ozone along with PM 2.5 in the air. AQI of 0 – 50 is good, 51 – 100 is moderate, 101 – 150 is poor, 151 – 200 is unhealthy, 201 –

300 is severe and above 300 is hazardous. The World Quality Report published in the second week of April, this year has placed 45 cities of India among the top 50 most polluted cities with New Delhi topping the list with annual average AQI of 169 in 2024.

In India, extreme levels of pollution were seen in November in Delhi, Punjab, Chandigarh, Haryana and Himachal Pradesh. Crop stubble-burning remained the major contributor to PM 2.5 levels, accounting for 60% of pollution during peak periods. Other major sources of pollution in the country included vehicular emissions, industrial discharges and construction dust.

In our country, the number of pollution monitoring stations has increased from 37 in 2015 to more than 1000 in 2023. These, however, cover less than a quarter of the country's requirement. Small cities remain unrepresented. The air quality guidelines fixed by CPCB, although lower than that fixed by WHO, has to be strictly monitored and implemented. Clean air is a fundamental right of the citizens. Urgent and sufficient steps are to be taken throughout the world. Otherwise, time may come, when we have to purchase clean air in bottle or pouch like the mineral water bottle we are now purchasing.

✍

Er. Mayadhar Swain  
Editor

2

## STORY OF THE ELECTRON: PART-17

<sup>1</sup>Balaram Sahoo  
<sup>2</sup>Prafulla Kumar Pujapanda

Einstein and Bohr were two well known titans of theoretical physics. They were engaged in one of the profound and influential dialogue of 20<sup>th</sup> century. Their debate on quantum mechanics has played a significant role in shaping our understanding of quantum mechanics and nature of reality.

Einstein did not like the way quantum mechanics turned after 1925. Undoubtedly he was excited by Heisenberg's matrix mechanics, Schrodinger's wave mechanics and Born's interpretation of the meaning of Schrodinger's wave equation i.e. the square of the wave function  $\psi^2$  is to be considered as probability density. However his conscience

told him that something was missing.

He wrote to Born "Quantum mechanics is very impressive. But an inner voice tells me that it is not yet the real thing. The theory produces a good deal but hardly brings us closure to the secret of the old one." The most familiar factoid (a piece of information that is stated as a fact but may not be entirely true) about Einstein's views on quantum mechanics "God does not play dice with the Universe" repudiates that he did not approve the theory in its final form.

### The Fifth Solvay Conference, 1927

The famous fifth Solvay Conference on Physics was held from 24<sup>th</sup> to 29<sup>th</sup> October 1927 at Brussels, the capital of Belgium. The subject was "Electron and Photon". World's most notable scientists, old masters and young Turks met to discuss newly formulated quantum theory. The leading figures were Albert Einstein and Niels Bohr. Out of 29 attendees 17 were Nobel prize winners. Madame Curie was amongst them who had won Nobel Prize in two separate scientific disciplines. The anti-German prejudice that had prevented Einstein and others from attending Solvay conference held after First World War

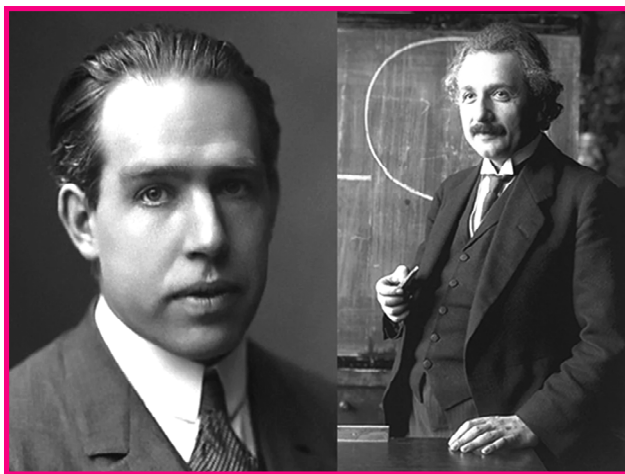

Niels Bohr

Albert Einstein



SOLVAY CONFERENCE 1927

- |                           |                            |                              |                            |                                |
|---------------------------|----------------------------|------------------------------|----------------------------|--------------------------------|
| 1 Peter Debye             | 7 Émile Henriot            | 13. Théophile de Donder      | 19 Paul Langevin           | 25 Charles Thomson Rees Wilson |
| 2. Irving Langmuir        | 8 Paul Ehrenfest           | 14 Paul Adrien Maurice Dirac | 20 Louis-Victor de Broglie | 26 Ralph Howard Fowler         |
| 3 Martin Knudsen          | 9 Marie Curie              | 15 Albert Einstein           | 21 Charles-Eugene Guye     | 27 Leon Brillouin              |
| 4. Auguste Piccard        | 10 Hendrik Anthony Kramers | 16 Erwin Schrödinger         | 22 Wolfgang Pauli          | 28 Niels Bohr                  |
| 5 Max Planck              | 11 Édouard Herzen          | 17 Arthur Holly Compton      | 23 Werner Heisenberg       | 29 Owen Wilans Richardson      |
| 6. William Lawrence Bragg | 12 Hendrik Antoon Lorentz  | 18 Jules-Émile Verschaffelt  | 24 Max Born                |                                |

### The fifth Solvay Conference, 24<sup>th</sup> to 29<sup>th</sup> October 1927

had dampened down. Importantly all those names who had contributed to the recent development of quantum theory were at the Conference including Bohr, Born, Louis de Broglie, Dirac, Heisenberg, Pauli and Schrodinger. Heisenberg commented “Through the possibility of exchange between the representatives of different lines of research this conference has contributed extraordinarily to the clarification of the physical foundation of Quantum Theory. It forms so to speak the outward completion of Quantum Theory.”

Hendrick Lorenz was the president of scientific committee and the chairman of the conference. After brief words of welcome from Lorenz the opening ceremony was addressed by William L. Bragg, Professor of

Physics at Manchester University. He reported the latest information concerning the reflection of X-rays by crystals and explained how these results gave information for a clear understanding of the atom. The American physicist Arthur Compton talked over the failure of electromagnetic theory of radiation in helping understanding of photoelectric effect and the increase in wavelength of X-rays when they were scattered by electrons. de Broglie reported his contribution on wave-particle duality of matter and the ingenious way Schrodinger developed the wave theory. He believed that electron really exists as a particle and a wave in sharp contrast to the Copenhagen interpretation which claims that electron behaves like either a particle or a

wave that depends upon the kind of experiment conducted.

Max Born and Werner Heisenberg declared that quantum mechanics was a complete theory. Its fundamental principles need no further modification. Their opinion effectively solidified the Copenhagen interpretation. Copenhagen interpretation suggests that quantum mechanics provides only probabilities of outcome, not definite prediction. Besides, the act of measurement plays a crucial role in determining the state of the system. Quantum mechanics embraced the inherent uncertainty and probabilistic nature of the theory. Heisenberg and Born emphasized that the quantum revolution was over and nothing further was needed. Their declaration was met with disagreement from Albert Einstein. He believed quantum mechanics was not yet a complete theory due to its reliance on indeterminacy.

In parallel, the Austrian physicist Erwin Schrodinger developed an alternative quantum theory based on wave properties of the electron. It led to the formulation leading to Schrödinger's equations. Schrodinger sent a copy of his published paper to Einstein who wrote back hailing his equations as a decisive advance of true genius.

When in 1926 Born and Heisenberg declared that quantum mechanics were to be understood as a probability without any causal explanation, both Einstein and Schrodinger rejected their interpretation stating that causality had been a key feature in old quantum mechanics.

## Bohr – Einstein Debate

Bohr - Einstein debates were a series of public difference of opinion between Albert Einstein and Niels Bohr about quantum mechanics. Their debates have become events of great importance to the philosophy of science. Their disagreement and the outcome of Bohr's version of quantum mechanics became the prevalent view that formed the root of the modern understanding of physics.

Most of Bohr's version of the events held in Solvay conference 1927 and other places were written by Bohr in an article titled "Discussion with Einstein in Epistemological Problem in Atomic Physics."

The article dealt on the philosophical issues of the debate whether Bohr's Copenhagen interpretation of quantum mechanics centered on his belief of complementarity was valid in explaining nature. Despite the difference of opinion between Bohr and Einstein the succeeding discussions were valuable in solidifying quantum mechanics. Bohr and Einstein maintained mutual admiration and respect that was to last the rest of their life.

On 28<sup>th</sup> October afternoon Lorenz invited Bohr to address the Solvay Conference. Bohr outlined that wave particle duality was an intrinsic feature of nature which could be explained on the principle of complementarity. The principle of complementarity underpinned the uncertainty principle. It exposed the limits of applicability of classical concepts. Earlier scientists believed that they were simply

passive observers of nature. But Copenhagen interpretation disagrees with this. It is never true in the atomic world. Bohr introduced the term 'Quantum Postulate' to explain the essence of the new physics. The term was introduced to explain discontinuity of nature due to indivisibility of quantum. In the postulate there was no clear separation of the observed and the observer. According to Bohr the reality did not exist in absence of observation. The Copenhagen interpretation emphasized the micro physical object has no intrinsic property. The electron does not exist at any place till an observation is made to locate it. It does not have any attribute like velocity till it is measured.

Einstein listened to Bohr carefully and after Bohr, he requested Lorenz to present some general remarks. His objective was to show that Copenhagen interpretation was inconsistent. He adopted his favorite method of the hypothetical thought experiment.

Einstein went to the Board and drew a

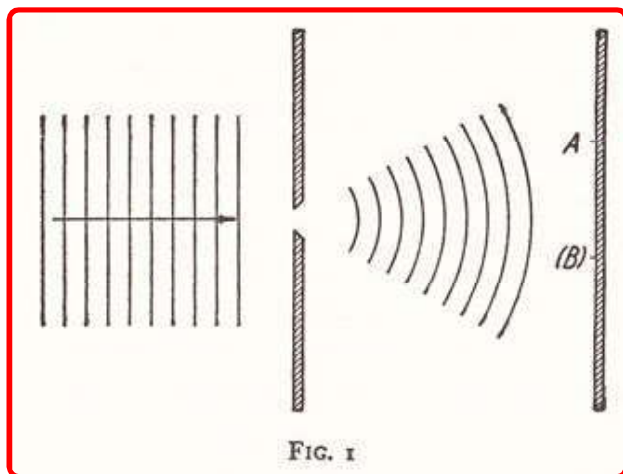

Figure 1: A later rendition by Bohr of Einstein's single-slit thought experiment

neat diagram (Figure 1), an opaque screen containing a narrow slit. Behind the screen, he drew curved lines (representing waves) and a photographic plate. Since the slit is narrow the electron will emerge as spherical waves in every possible direction. But the electron strikes the photographic plate like an independent particle.

Copenhagen interpretation suggests before the observation that there is no non-zero probability of detecting it at every point on the photographic plate i.e. the wave is spread at every point. The moment the particle is observed, say at point A the probability of detecting it at B or any other point turns out to be zero, the wave function collapses. Copenhagen interpretation claims that the quantum mechanics provide a complete description of the electron.

Einstein observed that prior to observation the probability of electron was smeared over the entire plate. The very moment the electron is observed at A, the probability at B or at any other point becomes zero. Such instantaneous collapse of the wave function violates the theory of relativity that nothing can travel faster than light.

Neil Bohr's elegant response to Einstein's proposed thought experiment was

.....*To be Continued at Page No.-202*



## 3

## ATOMS TO HUMANITY



Dr. Bibhuti Narayan  
Biswal

From tiny atoms, there came this vast universe,

A spark ignited as life- manifested as flora,  
fauna, and a tiny virus,

Through evolution's steady flow,

Changes manifest from single cells to tissues  
to organisms, to life as we grow.

Primates climbed, then walked upright,

Through curious minds, we discovered life's  
essentials and saw the light.

Right from stone tools to sharp, to crafted art,

The constant change brought modern human  
beings to play their part.

To meet our needs, we traversed delicate  
progressions and carved innovative ways,

Food, clothes, and shelter paved the day.

Communities merged, villages grew, then cities  
became vast,

A changing world became vibrant by evolving  
fast.

The wheel turned swiftly, and witnessed  
changes that triggered industrial revolutions

to come,

Industrial sparks, machines, and  
supercomputers came into being by igniting  
fame.

Machines and factories shaped every part of  
the land,

Many new dreams and modern civilizations  
emerged from human hands.

Economic liberalization worldwide opened  
doors,

Trade and ideas crossed geographical shores.

Globalization stitched life's well-knitted  
thread,

Binding nations, promoting scientific  
collaborations as pathways unfolded.

Technologies evolved linearly along the life's  
way,

Mechanised transportation, electrification,  
wireless communication, and aeroplanes  
touched the sky,

It changed the way we all live today,

Technology will make us slaves one day whose time is not far away

ICT revolutions aided the latest brave new Artificial Intelligence age,

Learning minds are at the crossroads of history's stage.

Artificial Intelligence is crossing all human barriers,

All Humans can see a possible danger.

Humans' greed brings irreversible changes,

Desertification, land infertilisation, and the growing threat of nuclear weapons.

The whole world is in a state of boiling chaos and confusion,

As if we are all directed to uncertain posterity and self-destruction.

Yet progress brought global warming, and ocean acidification with a heavy cost,

Earth's climate's equilibrium today is nearly lost.

Nature's call, arise, awake - a plea to heal,

Change demands that all humans act with great zeal.

Sustainability now holds the quantum key,

To shape the evolving world for all to see.

From small atoms to the next reverberating futures, *change is constant* and holds promise.

Embrace its flow, adapt, and strive; so that all can thrive.



Academic Lead,  
Reliance Foundation Schools Academic Council  
(RFSAC)  
Reliance Corporate Park, Navi Mumbai  
E-mail: bibhuti.nb@gmail.com

.....*Continuing from Page No.-200*

remarkable. According to Bohr the thought experiment of Einstein assumed that the screen and photographic plate had well defined positions in space and time. This could be possible only when both had infinite mass. Only in that case there would be no uncertainty in either place or time when the electron passed through the slit and emerged from it. In Einstein's thought experiment there is no possibility of uncertainty principle. Bohr argued a more realistic approach. Whatever the heaviness of the screen it would move when electron emerged through the slit. Even when the

movement is small and cannot be measured experimentally, it can still be made using the laboratory equipment of the human mind.

Since the screen moves the possibility of electron in space and time turns out to be uncertain. There will be corresponding uncertainty in momentum and energy. He logically concluded the screen through which the electron passes through is a quantum mechanical system.

To continue...



Vil, P.O: Gopapur,  
Dist: Cuttack, 754031

## 4 THE SCIENCE BEHIND GPS



Dr (Mrs.) Mridula  
Mishra

GPS, the abbreviation of ‘Global Positioning System’ is a much-uttered word in today’s technology enabled society. Many of us use this system to find the location of any place unknown to us. What is this system? How does it function? What is the working principle of this system? Understanding the answers of these questions is our concern.

### Introduction

Humans have been practicing navigation for thousands of years using the sun, moon, stars, and later the sextant. GPS technology has been used globally throughout history. The launch of Russia’s Sputnik satellite in 1957 ushered in the possibility of geolocation capabilities and soon after, the U.S. Department of Defense began using it for submarine navigation. In 1983, the U.S. government made GPS publicly available, but kept control of the available data. It was not until 2000 that companies and the public gained full access to the use of GPS, eventually paving the way for greater GPS advancement.

### Outline

GPS is a Global Navigation Satellite System. That means- it is a satellite navigation

system with global coverage. Now GPS is everywhere. The cars, smartphones and watches are all equipped with GPS. This navigation system uses satellites, a receiver, and algorithms to synchronize location, velocity and time data for air, sea, and land travel. The satellite system consists of a constellation of 30 satellites (a minimum of 24 satellites needed to be active at a given moment) revolving around the earth in an orbit at altitude around 20200 km with speed of 14000 km/h. These satellites are placed in six orbital planes separated by 60°, a configuration which ensures that at least four satellites can be seen from any point on the earth’s surface at a given moment. Three satellites are required to produce a location on earth’s surface, a fourth satellite is often used to validate the information from the other three. The space satellites, the ground control and user equipment are the three segments of GPS. The first segment is the satellites circling the earth, transmitting signals to users on geographical position and time of day. Second segment is the ground control. It is made up of earth-based monitor stations, master control

stations and ground antenna. The control activities include tracking and operating the satellites in space and monitoring transmissions. The monitoring stations are almost on every continent in the world. The third segment is the user equipment. It is the GPS receivers and transmitters including items like watches, smartphones and telematic devices.

### Functioning of GPS

The satellites broadcast continuous signals carrying information about their position and time. These signals are received by the GPS receivers, which calculate the radial distance of transmitting satellite to the receiver by multiplying the time taken by the signal to travel from the satellite to the receiver by the speed of light. But a single satellite cannot specify the exact location of a receiver. It can only infer an imaginary sphere centered at the transmitting satellite and with the GPS receiver at its periphery. Hence to exactly specify the location of the receiver, a minimum of three such spheres from three satellites and a fourth satellite to specify the precise timestamp is required. This geometrical arrangement of specifying location and time of receiver is known as the 'principle of trilateration'. It is the fundamental principle behind GPS location tracking. To understand the trilateration principle, let us first take single reference point that is one satellite. If a person is 10 km from a single point, then the person could be anywhere on a circle with a 10 km radius around that point. If the person adds another reference point (second satellite) and measure his distance from it, he will get a second circle. The intersection of

these two circles narrows down the location of the person to two possible points. A third reference point (third satellite) is used to eliminate one of the two locations, giving an exact position in two dimensions in terms of latitude and longitude. A fourth reference point (four satellites) helps to determine altitude, giving a precise three-dimensional location in terms of latitude, longitude, and altitude. Thus, each satellite's signal forms a sphere around it. The three equations of sphere with three satellites contain three unknown coordinates of the receiver position. A fourth satellite helps solve errors and improve accuracy. The system of equations is solved using matrix methods.

The signals travel at the speed of light. So, small timing errors can cause large position inaccuracies. To ensure precision, GPS relies on atomic clocks (which can measure the time with a few nanoseconds of accuracy) in satellites and sophisticated time synchronization techniques. The need of this incredible precision in time to determine the exact location makes the GPS system sensitive even to very small errors. There are some prominent static errors caused in the GPS due to the 'special theory of relativity' and 'general theory of relativity'.

'Length contraction' and 'time dilation' are the two most significant consequences of the 'special theory of relativity'. The GPS satellites move at a speed of 14,000 km/h, causing time to slow down by about 7 microseconds/day. This error of 7 microseconds, on multiplying by the speed of light, will translate into a spatial error in the

navigation, equal to about 2 km. So, in case GPS clocks are not regularly corrected for the errors caused by the time dilation, the navigation will get additional errors of the order of 2 km per day due to time dilation. Similarly due to ‘gravitational time dilation’ (the effects of ‘general theory of relativity’) clocks in strong gravitational fields move slower than those in weak fields. Hence, a clock nearer to the earth’s surface will move slower as compared to one located farther away. As the GPS satellites are 20200 km away from the earth’s surface, the atomic clocks present there move faster compared to the ones on the earth’s surface. This effect accumulates to give a net effect of approximately 45 microseconds per day. Hence, combining the time dilation of special theory of relativity and general theory of relativity, a net effect of speeding up of atomic clocks by around 38 microseconds per day would be evident. It would translate into the spatial stray of GPS navigation around 11 km per day, which would leave the GPS system of no use. Apart from these errors, there are also some dynamical errors like the slightest variation in the orbit of a satellite due to the tidal forces between sun and earth, impact of the varying electron density of atmospheric layers on the signals, etc. That is why the GPS receivers calculate time by comparing signals from multiple satellites, correcting for clock errors using a fourth satellite, and compensating for relativistic effects. This ensures precise timing, which is critical for navigation, communication networks and financial transactions.

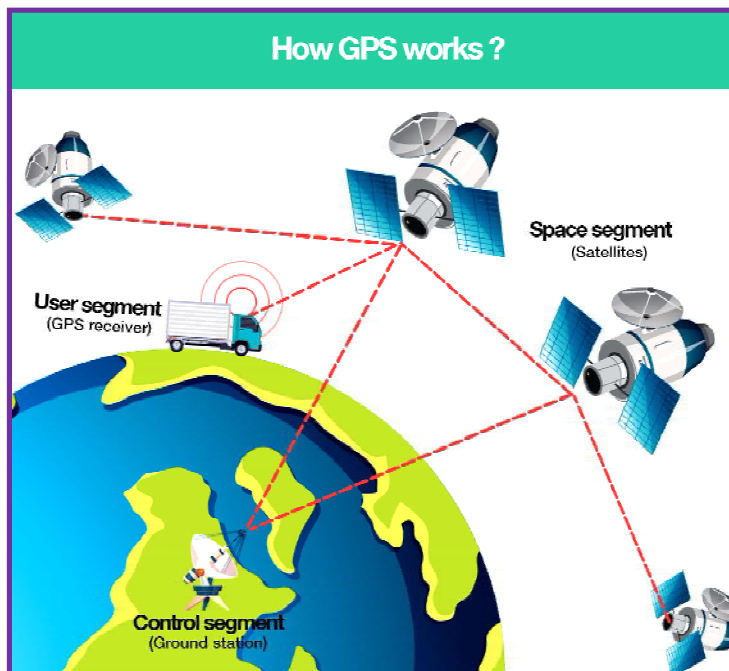

## Conclusion

Now-a-days GPS is a powerful and dependable tool with various uses. The five main uses of GPS are – Location, Navigation, Tracking, Mapping and Timing. Hence, surveyors, scientists, pilots, boat captains, workers in mining and farmers are the people who use GPS daily for their work. GPS is the navigation satellite system owned by USA. On similar lines, Russia, European Union, China, India, and Japan have their own navigation satellite systems. Indian regional navigation satellite system has an operational name, called NavIC. It is the acronym for Navigation with Indian Constellation. At present it covers India and a region extending 1500 km around it. And now it is mostly confined to strategic use by the Indian armed forces.

ଋ ଙ ଌ

Former Associate Professor in Physics  
B-102, Life Style Green Apartment  
KIIT Square, Bhubaneswar-24

5

LOGARITHMIC FUNCTION



Satyabrata Rout

If  $b > 0$  and  $b \neq 1$ , then the function defined by  $y = f(x) = \log_b x$ ,  $x > 0$  is called the logarithmic function. We say logarithm of  $x$  to base  $b$  is  $y$  if  $b^y = x$ .

i.e  $\log_b x = y \Leftrightarrow b^y = x$ .

The domain of the logarithmic function is the set of all positive real numbers and the range is the set of all real numbers.

i.e  $\log_b : \mathbb{R}^+ \rightarrow \mathbb{R}$ .

Case-1: When  $b > 1$ , In this case

$$y = \log_b x \begin{cases} < 0, & \text{if } 0 < x < 1 \\ = 0, & \text{if } x = 1 \\ > 0, & \text{if } x > 1 \end{cases}$$

Also, the values of  $y$  increase with the increase

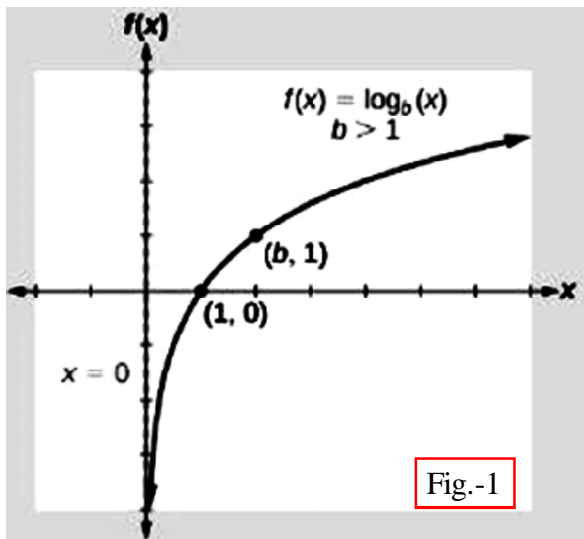

Fig.-1

in  $x$ . (fig.-1)

Case-2: When  $0 < b < 1$ , In this case

$$y = \log_b x \begin{cases} > 0, & \text{if } 0 < x < 1 \\ = 0, & \text{if } x = 1 \\ < 0, & \text{if } x > 1 \end{cases}$$

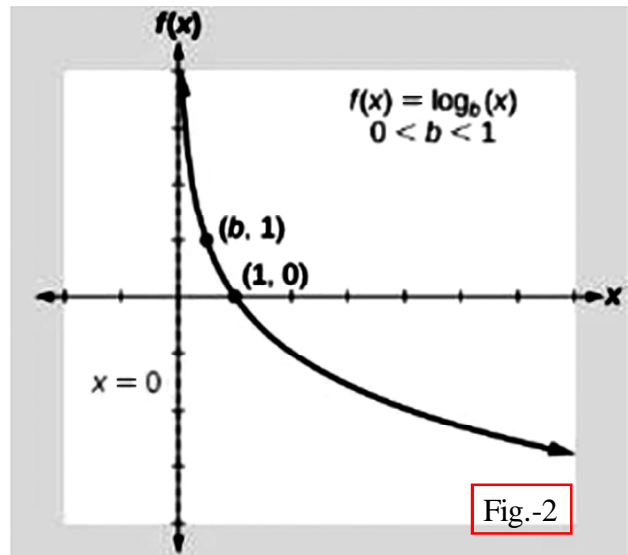

Fig.-2

Also, the values of  $y$  decrease with the increase in  $x$ . (fig.-2)

Some Properties of Logarithmic Function

1.  $\log_b(mn) = \log_b m + \log_b n$ , where  $b > 0, b \neq 1$  and  $mn > 0$

**Proof:** - Let  $\log_b m = x$ ,  $\log_b n = y$  and  $\log_b(mn) = z$

Now,  $\log_b m = x \Rightarrow b^x = m \dots \dots \dots (1)$

$$\log_b n = y \Rightarrow b^y = n \dots \dots \dots (2)$$

$$\log_b (mn) = z \Rightarrow b^z = mn \dots \dots \dots (3)$$

Put the value of m and n in equation – (3) we get,

$$\begin{aligned} b^z &= b^x b^y \\ \Rightarrow b^z &= b^{x+y} \\ \Rightarrow z &= x + y \dots \dots \dots (4) \end{aligned}$$

Put the value of x, y and z in equation – (4) we get,

$$\log_b (mn) = \log_b m + \log_b n, \text{ where } b > 0, b \neq 1 \text{ and } mn > 0$$

**2.**  $\log_b \left(\frac{m}{n}\right) = \log_b m - \log_b n, \text{ where } b > 0, b \neq 1 \text{ and } \frac{m}{n} > 0$

**Proof:** - Let  $\log_b m = x, \log_b n = y$  and  $\log_b \left(\frac{m}{n}\right) = z$

Now,  $\log_b m = x \Rightarrow b^x = m \dots \dots \dots (1)$

$$\log_b n = y \Rightarrow b^y = n \dots \dots \dots (2)$$

$$\log_b \left(\frac{m}{n}\right) = z \Rightarrow b^z = \frac{m}{n} \dots \dots \dots (3)$$

Put the value of m and n in equation – (3) we get,

$$\begin{aligned} b^z &= \frac{b^x}{b^y} \\ \Rightarrow b^z &= b^{x-y} \\ \Rightarrow z &= x - y \dots \dots \dots (4) \end{aligned}$$

Put the value of x, y and z in equation – (4) we get,

$$\log_b \left(\frac{m}{n}\right) = \log_b m - \log_b n, \text{ where } b > 0, b \neq 1$$

and  $\frac{m}{n} > 0$

**3.**  $\log_b m^n = n \log_b m, \text{ where } b > 0, b \neq 1 \text{ and } m^n > 0$

**Proof:** - Let  $\log_b m^n = x$  and  $\log_b m = y$ .

Now,  $\log_b m = y \Rightarrow b^y = m \dots \dots \dots (1)$

$$\log_b m^n = x \Rightarrow b^x = m^n \dots \dots \dots (2)$$

Put the value of m in equation – (2) we get,

$$\Rightarrow b^x = (b^y)^n \Rightarrow b^x = b^{ny}$$

$$\Rightarrow x = ny \dots \dots \dots (3)$$

Put the value of x and y in equation – (3) we get,

$$\log_b m^n = n \log_b m, \text{ where } b > 0, b \neq 1 \text{ and } m^n > 0$$

**4.**  $\log_{b^n} p^m = \frac{m}{n} \log_b p, \text{ where } b > 0, b \neq 1 \text{ and } p^m > 0, b^n > 0$

**Proof:** - Let  $\log_{b^n} p^m = x$  and  $p = y$ .

Now  $\log_b p = y \Rightarrow b^y = p \dots \dots \dots (1)$

$$= \log_{b^n} p^m = x \Rightarrow (b^n)^x = p^n \dots \dots \dots (2)$$

Put the value of p in equation – (2) we get,

$$b^{nx} = (b^y)^n \Rightarrow b^{nx} = b^{ny}$$

$$\Rightarrow nx = ny \Rightarrow x = \frac{m}{n} y \dots \dots \dots (3)$$

Put the value of x and y in equation – (3) we get,

$$\log_{b^n} p^m = \frac{m}{n} \log_b p, \text{ where } b > 0, b \neq 1 \text{ and } p^m > 0, b^n > 0$$

**5.**  $\log_{b^n} m = \frac{\log_a m}{\log_a b}, \text{ where } m > 0, a > 0, b < 0, a \neq 1 \text{ and } b \neq 1$

**Proof:** - Let  $\log_b m = x$  and  $\log_a m = y$  and  $\log_a b = z$

Now,

$$\log_b m = x \Rightarrow b^x = m \dots\dots\dots(1)$$

$$\log_a n = y \Rightarrow a^y = m \dots\dots\dots(2)$$

$$\log_a b = z \Rightarrow a^z = b \dots\dots\dots(3)$$

Put the value of b and m in equation – (1) we get,

$$a^{zx} = a^y$$

$$\Rightarrow zx = y$$

$$\Rightarrow x = \frac{y}{z} \dots\dots\dots(4)$$

Put the value of x, y and z in equation –(4) we get,

$$\log_b m = \frac{\log_{a^m}}{\log_{a^b}}, \text{ where } m > 0, a > 0, b > 0,$$

$a \neq 1$  and  $b \neq 1$ .

**6.**  $\log_b b = 1$ , where  $b > 0$  and  $b \neq 1$

Proof: - Let  $\log_b b = x$ .

$$\text{Now } \log_b b = x \Rightarrow b^x = b$$

$$\Rightarrow b^x = b^1$$

$$\Rightarrow x = 1$$

$$\Rightarrow \log_b b = 1, \text{ where } b > 0 \text{ and } b \neq 1$$

**7.**  $\log_b 1 = 0$ , where  $b > 0$  and  $b \neq 1$

Proof: - Let  $\log_b 1 = x$ .

$$\Rightarrow b^x = 1$$

$$\Rightarrow b^x = b^0$$

$$\Rightarrow x = 0$$

**8.**  $b^{\log_b m} = m$ , where  $b > 0$ ,  $b \neq 1$  and  $m > 0$

Proof: - Let  $b^{\log_b m} = x$ .

$$\Rightarrow \log_b x = \log_b m$$

$$\Rightarrow x = m$$

$$\Rightarrow b^{\log_b m} = m, \text{ where } b > 0, b \neq 1, m > 0$$

**9.**  $m^{\log_b n} = n^{\log_b m}$ , where  $b > 0$ ,  $b \neq 1$ ,  $m > 0$  and  $n > 0$

Proof: - Let  $m^{\log_b n} = x$  and  $n^{\log_b m} = y$

$$\text{Now, } m^{\log_b n} = x$$

Log both side base b we get,

$$\log_b n^{\log_b m} = \log_b x \dots\dots\dots(1)$$

$$n^{\log_b m} = y$$

Log both side base b we get,

$$\log_b n^{\log_b m} = \log_b y \dots\dots\dots(2)$$

Comparing equation (1) and (2) we get,

$$\Rightarrow \log_b x = \log_b y$$

$$\Rightarrow x = y$$

Putting the value of the x and y we get,

$$m^{\log_b n} = n^{\log_b m}, \text{ where } b > 0, b \neq 1, m > 0 \text{ and } n > 0$$

$$\mathbf{10.} \log_b m = \frac{1}{\log_m b}, \text{ where } m > 0, b > 0, m \neq 1$$

and  $b \neq 1$ .

**Proof:** - Let  $\log_b m = x$  and  $\log_m b = y$

$$\text{Now, } \log_b m = x \Rightarrow b^x = m \dots\dots\dots(1)$$

$$\log_m b = y \Rightarrow m^y = b \dots\dots\dots(2)$$

Put the value of m in equation – (2) we get,

$$\Rightarrow (b^x)^y = b \Rightarrow b^{xy} = b^1$$

$$\Rightarrow xy = 1$$

$$\Rightarrow x = \frac{1}{y} \dots\dots\dots(3)$$

Putting the value of x and y in equation – (4) we get,

$$\log_b m = \frac{1}{\log_m b}, \text{ where } m > 0, b > 0, m \neq 1$$

and  $b \neq 1$ .

\*Common logarithm(log):

$$\log_{10} x = y \Rightarrow 10^y = x \text{ [base = 10]}$$

\* Natural logarithm(ln):

$$\log_e x = y \Rightarrow \ln x = y \Rightarrow e^y = x \text{ [base = e]}$$

Where e is an irrational number. The value of  $e = 2.71828$  (approximately)

\* Anti-logarithms (Antilog): -The antilog, which is also known as “Anti-logarithms of a number is the inverse technique finding the logarithm of the same number.

If x is the logarithm of a number y with base b.

$$\text{i.e } \log_b y = x \Rightarrow y = \text{anti } \log_b x$$

Example: -

$$\text{Anti } \log_{10}(0) = 10^0 = 1, \text{ Anti } \log_{10}(10) = 10^1,$$

$$\text{Anti } \log_2(1.5) = 2^{1.5} \text{ and Anti } \log_5(3) = 5^3$$

### Some Problem of Logarithmic Function:

1. Find the value of  $\log_{10} 20$ .

$$\text{Sol: - } \log_{10} 20 = \log_{10} (4 \times 5)$$

$$= \log_{10} 4 + \log_{10} 5 = \log_{10} 2^2 + \log_{10} 5$$

$$= \log_{10} 2^2 + \log_{10} \frac{10}{2}$$

$$= 2 \log_{10} 2 + \log_{10} 10 - \log_{10} 2$$

$$= \log_{10} 2 + \log_{10} 10$$

$$= 0.3010 + 1$$

$$= 1.3010$$

2. If  $y = \log_b x$  where  $b > 0, b \neq 1$  and  $x > 0$ ,

$$\text{then } \frac{dy}{dx} = \frac{1}{x \ln b}$$

Proof: -

$$\frac{dy}{dx} = \lim_{h \rightarrow 0} \frac{\log_b (x+h) - \log_b x}{h}$$

$$= \lim_{h \rightarrow 0} \frac{\log_b \left( \frac{x+h}{x} \right)}{h}$$

$$= \lim_{h \rightarrow 0} \frac{\log_b \left( 1 + \frac{h}{x} \right)}{h}$$

$$= \lim_{h \rightarrow 0} \frac{1}{x} \lim_b \left( 1 + \frac{h}{x} \right)$$

$$= \lim_{h \rightarrow 0} \frac{1}{x} \lim_{h \rightarrow 0} \frac{x}{h} \log_b \left( 1 + \frac{h}{x} \right)$$

$$= \frac{1}{x} \lim_{h \rightarrow 0} \log_b \left( 1 + \frac{h}{x} \right)^{\frac{x}{h}}$$

$$= \frac{1}{x} \log_b e$$

$$= \log_b e$$

$$= \frac{1}{x \ln b}$$

3. If  $y = \ln x$ , where  $x > 0$ , then  $\frac{dy}{dx} = \frac{1}{x}$

$$\text{Proof: - } \frac{dy}{dx} = \lim_{h \rightarrow 0} \frac{\ln (x+h) - \ln x}{h}$$

$$= \lim_{h \rightarrow 0} \frac{\ln \left( \frac{x+h}{x} \right)}{h} = \lim_{h \rightarrow 0} \frac{\ln \left( 1 + \frac{h}{x} \right)}{h}$$

.....To be Continued at Page No.-229

6

## PHOTOSYNTHESIZING ANIMAL CELL CREATED



<sup>1</sup>Dr. Ramesh Chandra Parida

<sup>2</sup>Dr. Sachidananda Muni

One of the main architects of the wholesome environment and ecology that made the earth habitable and paved the way for the evolution of complex life forms in it, is the process of photosynthesis, carried on by green plants and some microorganisms like cyanobacteria (blue-green algae) and some other algae. In fact cyanobacteria were the unicellular organisms (phytoplanktons) that survive in fresh as well as saline water, were the first to carry on oxygenic photosynthesis that triggered the so called Great Oxygenation Event (GOE) about 2.4 billion years ago. Then those, along with green plants generated oxygen to bring its level in the atmosphere that allowed the evolution of air – breathing complex life forms on earth to begin about 1.75 billion years from now and simultaneously removing carbon dioxide, a green house gas, from it thereby cooling it to a temperature in which they can survive and flourish. Oxygen produced by photosynthesis is also responsible for the formation of the ozone layer that protects all the living beings from the high energy ultra violet radiation of the sun.

Mostly green plants and other organisms like algae are capable of carrying on this life

sustaining natural process because of the presence of chlorophyll, a green pigment contained in a structure in their cells, called chloroplast. The Nature has bestowed upon them this wonderful capability to generate their own food by using sunlight to convert carbon dioxide and water into a sugar (glucose) in presence of chlorophyll and the process can be represented by the following chemical reaction :

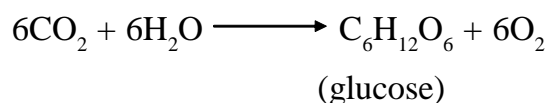

Animals are not capable of carrying on photosynthesis because their cells donot have chloroplast. However, recently a team of Japanese scientists led by Prof. Sachihiro Matsunagat of the University of Tokyo have successfully engineered animal cells that can do it. Usually animal cells consume oxygen, eat and break down sugar (glucose) and emit carbon dioxide, which is a completely opposite process to photosynthesis. By introducing photosynthetic properties into those, the Matsunagat's team hopes to create cells that consume less oxygen and sugar and emit less carbon dioxide.

# Process of Photosynthesis

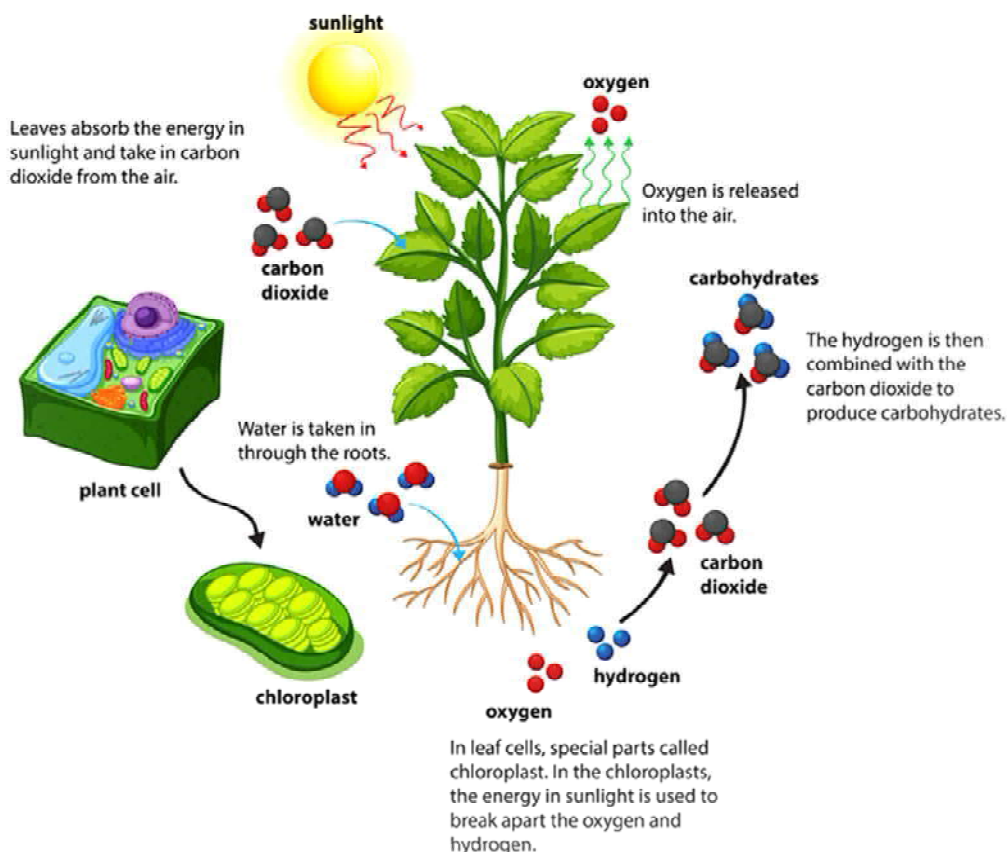

The attempts to create animal cells that can carry on photosynthesis began in 1970's. However, it is not an easy task as it requires convincing those to accept chloroplasts, the cellular structures that hold chlorophyll necessary for it. It is because the animal cells are at a higher temperature (about 37°C) than the plant cells (about 30°C) and besides, the animal cells also consider those as invaders like bacteria or viruses and their immune system destroys those. That is why such efforts remained unsuccessful.

“Incorporation of photosynthetically active chloroplasts in cultured mammalian cells towards photosynthesis in animals”

(Ryota Aloki et al) published in the journal “Proceedings of the Japan Academy, Series B” (October 2024) Matsunaga and his co-workers have reported to have achieved this scientific breakthrough, that redefined biological boundaries. Since chloroplasts survive in plant cells at a lower temperature, they searched for those that can tolerate the warmer environment of the animal cells. Then the team had to find a process which can prevent the animal cells from rejecting those. It achieved the objectives by selecting chloroplasts that can remain active at 37°C temperature from a primitive unicellular algae called Schyzon (Cyanidioschyzon merolae) which grows in a

volcanic hot spring in Italy at 42°C and then inserting those into the cultured hamster cells, thereby making what are now called as “planimal cells”. The insertion process was carried on by allowing the animal cells to digest chloroplasts as ‘food’ rather than fortifying those by implantation. It could bypass the immune response that destroys the ‘invaders’. As a result, those could be maintained inside the cells for at least two days in which initial reactions of photosynthesis could be detected. Besides, the cells also showed an increased growth rate, suggesting that the chloroplasts provided an additional energy source.

Then the researchers examined the structures of chloroplasts within the cells by using different imaging techniques (such as confocal microscopy, super – resolution microscopy and electron microscopy) and confirmed that the electron transport of photosynthetic activity was occurring by using pulses of light, a technique called pulse amplitude modulation fluorometry.

According to Matsunaga, during the process of artificially growing tissues, the cells become multilayered and the interior of the cell mass do not get enough oxygen. Therefore, cell division as well as size increases stops. However, when embedded with chloroplasts, these cell clusters can generate their oxygen when exposed to light. As a result, cell division and growth can occur.

He and his co – workers believe that soon their work will be useful for cellular tissue engineering to make lab grown tissues

such as artificial organs, meat, skin sheets etc. Of course, it may not be easy and may need enormous research efforts to make synthesizing human cells and those of higher animals, but their scientific achievement which has opened doors for increasing the life span of chloroplasts in animal cells and thus, those can carry on photosynthesis for as long as possible, may soon make those possible, they claim.

The team is now continuing its research on creating “planimal cells” of many kinds of animals using chloroplasts from different sources, so that the life spans of those chlorophyll containing structures in animal cells can be increased indefinitely where those can continue to carry on photosynthesis for prolonged periods.

When that is achieved it can also have many important medical applications that can deliver oxygen to specific organs such as heart. As for example, by implanting a small LED near the heart could provide light to photosynthetic cells in it, thereby improving oxygen delivery to heart of the patients. Besides, such medical and veterinary uses those can also be used to meet the challenges in food production and possibly in climate change.

✪ ● ✪

<sup>1</sup>Retired Professor of Chemistry,  
College of Basic Science & Humanities  
Odisha University of Agriculture & Technology,  
Usha Nivas, 124/2445, Khandagiri Vihar,  
Bhubaneswar-30

email: paridanana47@gmail.com

<sup>2</sup>Assistant Professor of Chemistry  
College of Basic Science & Humanities,  
OUAT, Bhubaneswar-03

email: sachidanandamuni@yahoo.com

7

## INVALUABLE CAMPHOR TREE



<sup>1</sup>Dr. Rajballav Mohanty  
<sup>2</sup>Dr. Taranisen Panda

Camphor is an aromatic, crystalline, volatile and flammable compound that is waxy and white in colour. It is an essential item in our daily life as required in our religious rituals as incense, in cough, pain and itching, for insect bites and some other illness and use in products like vicks vaporub. Camphor oil is one of the commonly used oils in medicine and considered an effective household remedy for many ailments. But, few people know that it is a plant product which is generated in the wood of a tree called “Camphor tree”.

### Characters of Camphor Tree

The scientific name of camphor producing tree is *Cinnamomum camphora* (L.) Presl., Family-Lauraceae. It is a perennial, evergreen tree species, indigenous to temperate and subtropical climate of East Asia including countries like China, Taiwan, Vietnam, Korea and Japan. In India, it grows in Western Ghats, Eastern Himalays and Andaman Islands. A new species of camphor tree, named *Cinnamomum agasthyamalayana* is found growing in Agasthyamalai hills of Kerala. But *Cinnamomum comphora* is a common cultivated species of camphor tree, that is used as an ornamental and a source of camphor.



It is a massive, perennial plant growing upto 30 m. in height and with a trunk circumference above 20 m. The plant is profusely branched, leaves simple, having a glossy and waxy appearance and with the smell of camphor when crushed. In spring, it produces small, white fragrant flowers from which develops clusters of black berry like fruits. Camphor is chemically a terpenoid and a cyclic ketone with chemical formula  $C_{10}H_{16}O$ , which is naturally produced in the wood of the camphor tree in form of a waxy, colourless solid and with a strong aroma.

### Extraction of Camphor and Camphor Oil

Camphor is extracted from the wood by steam distillation process. In this process,

steam is made to pass through the chipped or pulverized stem and the vapours are condensed to produce camphor. In fact, camphor crystallized from the oily portion of the distillate and then purified by processing and sublimation. Some other extraction methods include (a) superficial CO<sub>2</sub> extraction, (b) Organic solvent extraction and (c) Ionic liquid combined with microwave assisted extraction method.

The essential camphor oil is extracted from the leaves by steam distillation method. It is a mixture of volatile compounds, mainly terpenes and is widely used in medicine, perfume and in chemical industries.

### Properties and uses of Camphor

Camphor is a white, crystalline powder with translucent character. It has a strong mothball like odour, which is fragrant and penetrating. It is less dense than water and will float, but does not dissolve in water. Moreover, camphor is flammable and volatile. It can quickly evaporate and change from a solid to

a gas. Camphor is used as a flavouring agent in various dishes. But, it has toxic effects when consumed directly.

### Medicinal Use

Camphor has a variety of uses including medicinal use. Traditional herbalists utilizes camphor for resuscitation, heat clearance and pain relief. It is often used to recover from fever, convulsions, stroke, sputum fainting, sputum coma, laryngeal pin, mouth pain, Anthrax and blood shot eyes. Traditional healers claim uses like treating pain, warts,

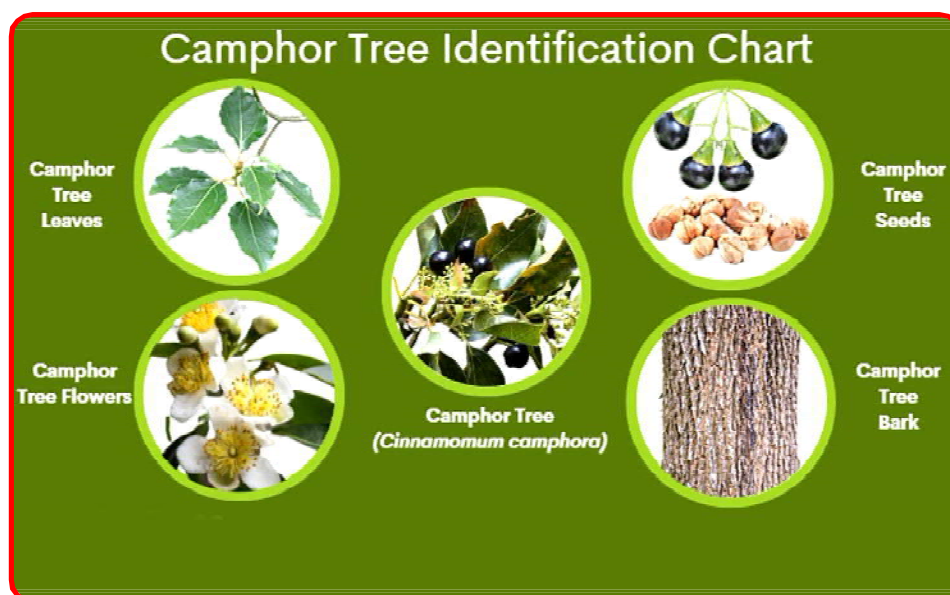



cold sores, hemorrhoids, osteoarthritis, etc. can be beneficial. It is claimed to be antitussive, analgesic and anesthetic in property. In fact, it has antibacterial, anti-fungal and anti-inflammatory properties. With a strong fragrant odour, it is used to treat cold and congestion, for pest control, as an air freshener and for centuries used in religious rituals as incense. It is also used as a mosquito and other harmful pest repellent.

### Industrial and other Miscellaneous Uses

Camphor is used in making drugs and ointments, smokeless powder for ammunition, plastics, insecticides, furniture polish, nail polish etc. It is also used as an industrial plasticizer and in food and beverage flavoring. Its soothing and cooling effect is evident in the sprays, balms, creams and various

ointments made from camphor. Today camphor is also synthetically produced from Turpentine oil, but the importance and demand of naturally produced camphor from the camphor plant is not diminished at all.

A camphor tree can live for 50 to 150 years and provides us the unique fragrant material with its numerous utility. But it is a matter of great concern that the camphor tree all over the world is now endangered and faces a risk of extinction due to its indiscriminate use and over exploitation. Same is the situation in India, which warrants immediate conservation measure to save this invaluable species.

✪ ● ✪

<sup>1</sup>Ex-Reader in Botany, Plot No. 1311/7628, Satya Bihar, Rasulgarh, Bhubaneswar-751010

<sup>2</sup>Department of Botany, Chandbali College, Chandbali, Bhadrak- 756133, Odisha, India  
Email: taranisenpanda@yahoo.co.in

8

## MULTIFARIOUS BENEFITS OF AMAZING PLANT BAMBOO



Dr. Sadasiva Biswal

### Prelude

Bamboos are a diverse group of mostly evergreen perennial flowering plants making up the subfamily Bambusoideae of the grass family Poaceae. Giant bamboos are the largest members of the grass family, in the case of *Dendrocalamus Sinicus* having individual stalks (Culms) reaching a length of 46 meters, up to 36 centimeters in thickness and a weight of up to 450 kilograms. The internodes of bamboos can also be of great length. *Kinabaluchloa Wrayi* has internodes up to 2.5 meters in length, and *Arthrostylidium Schomburgkii* has internodes up to 5 meters in length, exceeded in length only by papyrus. By contrast, the stalks of the tiny bamboo *Raddiella Vanessiae* of the Savannas of French Guiana measure only 10-20 millimeters in length by about 2 millimeters in width. The origin of the word “bamboo” is uncertain, but it probably comes from the Dutch or Portuguese language, which originally borrowed it from Malay or Kannada.

Bamboos includes some of the fastest-growing plants in the World, due to a unique rhizome-dependent system. Certain Species of Bamboo can grow 91 centimeters within a

24-hour period, at a rate of almost 40 millimeters an hour equivalent to 1mm every 90 seconds. Growth up to 120 cms in 24 hours has been observed in the instance of Japanese giant timber bamboo. This rapid growth and tolerance for marginal land, make bamboo a good candidate for afforestation, carbon sequestration and climate change mitigation.

Bamboo is versatile and has notable economic and cultural significance in South Asia, South-east Asia, and East Asia, being used for building materials, as a food source, and as a raw product, and depicted often arts, such as in bamboo paintings and bamboo working. Bamboo, like wood, is a natural composite material with a high strength-to-weight ratio useful for structures. Bamboo’s strength-to-weight ratio is similar to timber, and its strength is generally similar to a strong softwood or hardwood timber. Some bamboo species have displayed remarkable strength under test conditions. *Bambusa tulda* of Bangladesh and adjoining India has tested as high as sixty thousand Psi (400 Mpa) in tensile strength<sup>10</sup>. Other bamboo species make extraordinarily hard material. *Bambusa*

tabacaria of china contains so much silica that it will make sparks when struck by an axe.

## Ecology

The two general patterns for the growth of bamboo are “Clumping”, and “running”, with short and long underground rhizomes, respectively. Clumping bamboo species tend to spread slowly, as the growth pattern of the rhizomes is to simply expand the root mass gradually, similar to ornamental grasses. Running bamboos need to be controlled during cultivation because of their potential for aggressive behavior. They spread widely underground and send up new culms to break through the surface.

Running bamboo species are highly variable in their tendency to spread; this is related to the species, soil and climate conditions. Some send out runners of several meters, a year, while others stay in the same general area for long periods. If neglected, over time, they can cause problems by moving into adjacent areas.

Unlike all trees, individual bamboo culms emerge from the ground at their full diameter and grow to their full height in a single growing season of three to four months. During this time, each new shoot grows vertically into a Culm with no branching out until the majority of the mature height is reached. Then, the branches extend from the nodes and leafing out occurs. In the next year, the pulpy wall of each Culm slowly hardens. During the third year, the Culm hardens further. The shoot is now a fully mature Culm. Over the next 2-5 years (depending on species), fungus begins to form

on the outside of the Culm, which eventually penetrates and over-comes the Culm. Around 5-8 years later (species and climate-dependent), the fungal growths cause the Culm to collapse and decay. This brief life means culms are ready for harvest and suitable for use in construction within about three to seven years. Individual bamboo culms do not get any taller or larger in diameter in subsequent years than they do in their first year, and they do not replace any growth lost from pruning or natural breakage. Bamboo has a wide range of hardiness depending on species and locate. Small or young specimens of an individual species produce small Culms initially. As the Clump and its rhizome system mature, taller and larger Culms are produced each year until the plant approaches its particular species limits of height and diameter.

Many tropical bamboo species die at or near freezing temperatures, while some of the hardier temperate bamboos survive temperatures as low as  $-29^{\circ}\text{C}$ . Some of the hardiest bamboo species are grown in USDA plant hardiness zone5, although they typically defoliate and may even lose all above-ground growth, yet the rhizomes survive and send up shoots again the next spring. In milder climates, such as USDA zone7 and above, most bamboo remain fully leafed out and green year-round.

## Mass Flowering

Bamboos seldom and un-predictably flower and the frequency of flowering varies greatly from species to species. Once flowering takes place, a plant declines and

often dies entirely. In fact, many species only flower at intervals as long as 65 or 120 years. These taxa exhibit mass flowering (or gregarious flowering), with all plants in a particular 'Cohort' flowering over a several-year period. Any plant derived through clonal propagation from this cohort will also flower regardless of whether it has been planted in a different location. The longest mass flowering interval known is 120 years, and it is for the species *Phyllostachys bambusoides*. In this species all plants of the same stock flower at the same time, regardless of differences in geographic locations or climatic conditions, and then the bamboo dies<sup>13</sup>. The commercially important bamboo *Guadua*, or *Cana brava* (*Guadua angustifolia*) bloomed for the first time in recorded history in 1971, suggesting a blooming interval well in excess of 130 years. The lack of environmental impact on the time of flowering indicates the presence of some of sort of "alarm clock" in each cell of the plant which signals the diversion of all energy to flower production and the cessation of vegetable growth. This mechanism, as well as the evolutionary cause behind it, is still largely a mystery.

### Invasive Species

Some bamboo species are acknowledged as having been commissioned by International Bamboo and Rattan Organization, found that invasive species typically are varieties that spread via rhizomes rather than by clumping, as most commercially viable woody bamboos do. In the United States, the National Invasive Species Information Center agency of the

department of Agriculture has Golden Bamboo (*Phyllostachys aurea*) listed as an invasive species.

### Uses of Bamboo

#### (i) Culinary

The shoots of most species are edible either raw or cooked, with the tough sheath removed. Cooking removes the slight bitterness. The shoots are used in numerous Asian dishes and broths, and are available in supermarkets in various sliced forms, in both fresh and Canned Versions.

The bamboo shoot in its fermented state forms an important ingredient in cuisines across the Himalayas. In Assam, India, for example, it is called khorisa. In Nepal, a delicacy popular across ethnic boundaries consists of bamboo shoots fermented with turmeric and oil, and cooked with potatoes into a dish that usually accompanies rice (alu tama) in Nepali.

In Indonesia, they are sliced thin and then boiled with santan (thick coconut milk) and spices to make a dish called gulai rebung. Other recipes using bamboo shoots are sayur lodeh (mixed vegetables in coconut milk) and lun pia (sometimes written lumpia: fried wrapped bamboo shoots with vegetables). The shoots of some species contain toxins that need to be leached or boiled out before they can be eaten safely.

Pickled bamboo, used as a Condiment, may also be made from the pith of the young shoots. The sap of young stalks tapped during the rainy season may be fermented to make



ulanzi (a sweet wine) or simply made in to a soft drink. Bamboo leaves are also used as wrappers for steamed dumplings which usually contains glutinous rice and other ingredients, such as the Zongzi from China.

### Animal diet

Bamboo contains large amounts of protein and very low amounts of carbohydrates allowing this plant to be the source of food for many animals. Soft bamboo shoots, stems and leaves are the major food source of the giant panda of China, the red panda of Nepal, and the bamboo lemurs of Madagascar. The red panda can eat up to 4.1 kg a day which is a also about the full body weight of the animal. With raw bamboo containing trace amounts of harmful cyanide with higher concentrations in bamboo shoots, the golden bamboo lemur ingests many times the quantity of the taxiphyllin-containing bamboo that would be lethal to a human.

Mountain gorillas of central Africa also feed on bamboo, and have been documented consuming bamboo sap which was fermented and alcoholic ; chimpanzees and elephants of the region also eat the stalks. The larvae of the bamboo borer (the mothomphisafuscidentails) of Laos, Myanmar, Thailand and Yunnan, China feed off the pulp of live bamboo. In turn, these caterpillars are considered a local delicacy. Bamboo is also used for livestock feed with research showing some bamboo varieties have higher protein content over other varieties of bamboo.

### Man's diet

Pickled bamboo, used as a condiment,

may also be made from the pith of the young shoots. The sap of young stalks tapped during the rainy season may be fermented to make ulanzi (a sweet wine) or simply made into a soft drink.

Pickled bamboo shoots (Nepali : tama) are cooked with black-eyed beans as a delicacy in Nepal. Many Nepalese restaurants around the world serve this dish as aloo bodi tama. Fresh bamboo shoots are sliced and pickled with mustard seeds and turmeric and kept in glass jar in direct sunlight for the best taste. It is used alongside many dried beans in cooking during winters. Baby shoots (Nepali : tusa) of a very different variety of bamboo (Nepali : Nigalo) native to Nepal is cooked as a curry in hilly regions.

In Sambalpur, India, the tender shoots are grated into juliennes and fermented to prepare karadi. The name is derived from the Sanskrit word for bamboo shoot, karira. This fermented bamboo shoot is used in various culinary preparations, notably amil, a sour vegetable soup. It is also made into pancakes using rice flour as a binding agent. The shoots that have turned a little fibrous are fermented, dried, and ground to sand-sized particles to prepare a garnish pumpkin leaves to make sag green leaves. In konkani cuisine, the tender shoots (kirlu) are grated and cooked with crushed jackfruit seeds to prepare kirla sukke.

In southern India and some regions of south West China, the seeds of the dying bamboo plant are consumed as a grain known as "bamboo rice". The taste of cooked bamboo seeds is reported to be similar to wheat and the

appearance similar to rice, but bamboo seeds have been found to have lower nutrient levels than both. The seeds can be pulverized into a flour with which one can make cakes. The Indian state of Sikkim has promoted bamboo water bottles to keep the state free from plastic bottles.

The empty hollow in the stalks of larger bamboo is often used to cook food in many Asian cultures. Soups are boiled and rice is cooked in the hollows of fresh stalks of bamboo directly over a flame. Similarly, steamed tea is sometimes rammed into

musical instrument (Banshi), stick of the umbrella, ornaments, Kula, Nalia, flag-pole, sticks for the use of the elderly people and so many other varieties of items. People of Assam prepare many items from bamboo, including toys for children and the images of various deities. So, Bamboo industry in small scale has been created. Mainly women of a family are engaged in preparing things from Bamboo with beautiful structures. It is very much observed in the regions of North-Eastern states of India.



bamboo hollows to produce compressed forms of pure tea. Cooking food in bamboo is said to give the food a subtle but distinctive taste.

### Bamboo Working

Bamboo working is the activity or skill of making items from bamboo, and includes architecture, carpentry, furniture and cabinetry, carving, joining, and weaving. Its historical roots in Asia span cultures, civilizations, and millennia and is found across East, South, and Southeast Asia.

Various household articles are made from bamboo, such as baskets, handmade fans,

### Writing Surfaces:

Bamboo was in widespread use in early China as a medium for written documents. The earliest surviving examples of such documents, written in ink on string-bound bundles of bamboo strips (or “slips”), date from the fifth century BC during the warring states period. References in earlier texts surviving on other media indicate some precursor of these

*.....To be Continued at Page No.-235*

9

## PRESERVING THE OLIVE RIDLEY TURTLES IN ODISHA: A CONSERVATION SUCCESS STORY UNFOLDS

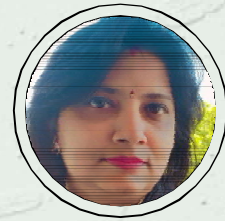

Subhra Patra

Odisha has once again made history in marine conservation as 6.82 lakh Olive Ridley turtles have arrived along its coastline for their annual mass nesting, also known as Arribada. This rare and breathtaking natural phenomenon has been witnessed at the Rushikulya river mouth in Ganjam district, one of the largest nesting sites for these endangered sea turtles.

The event, which began on February 16, 2024, continued until February 25, according to the Rushikulya Sea Turtle Protection Group. Conservationists, researchers, and wildlife enthusiasts celebrated this recordbreaking nesting season as a major milestone in India's marine conservation efforts.



Odisha is one of the very few places in the world where such a mass nesting phenomenon takes place. The state's continuous conservation efforts, along with community participation and government initiatives, have contributed to the protection of these magnificent marine creatures.

### The Unique Mass Nesting Behavior of Olive Ridley Turtles

The Olive Ridley turtles (*Lepidochelys olivacea*), named for their olive-green shells, are one of the smallest sea turtle species in the world. What makes them unique is their synchronized mass nesting behavior, called Arribada—a Spanish term meaning 'arrival.'

Unlike other sea turtles that nest individually, Olive Ridelys arrive in thousands, often under moonlit skies, to lay their eggs in a synchronized manner. Scientists believe this behavior helps them protect their nests from predators such as jackals, birds, and crabs.

After laying around 80-120 eggs each, the mother turtles return to the ocean, leaving the eggs to incubate naturally in the warm sand. After 45-60 days, hatchlings emerge and instinctively crawl toward the sea, guided by

the natural light reflection on the ocean's surface.

### Why Do Olive Ridley Turtles Choose Odisha's Coast?

Odisha's coastline is among the few places in the world that witness Arribada, making it a crucial site for global turtle conservation. The three major nesting sites in Odisha are:

#### 1. Gahirmatha Marine Sanctuary (Kendrapara District)

- ◆ The world's largest rookery for Olive Ridley turtles.

- ◆ Declared a marine sanctuary in 1997 to protect turtle nesting grounds.

#### 2. Rushikulya River Mouth (Ganjam District)

- ◆ The second-largest nesting site in Odisha.
- ◆ Known for consistent mass nesting events over the years.
- ◆ One of the few sites where human intervention is minimal, making it an undisturbed nesting habitat.

#### 3. Devi River Mouth (Puri District)

- ◆ Another significant nesting ground.

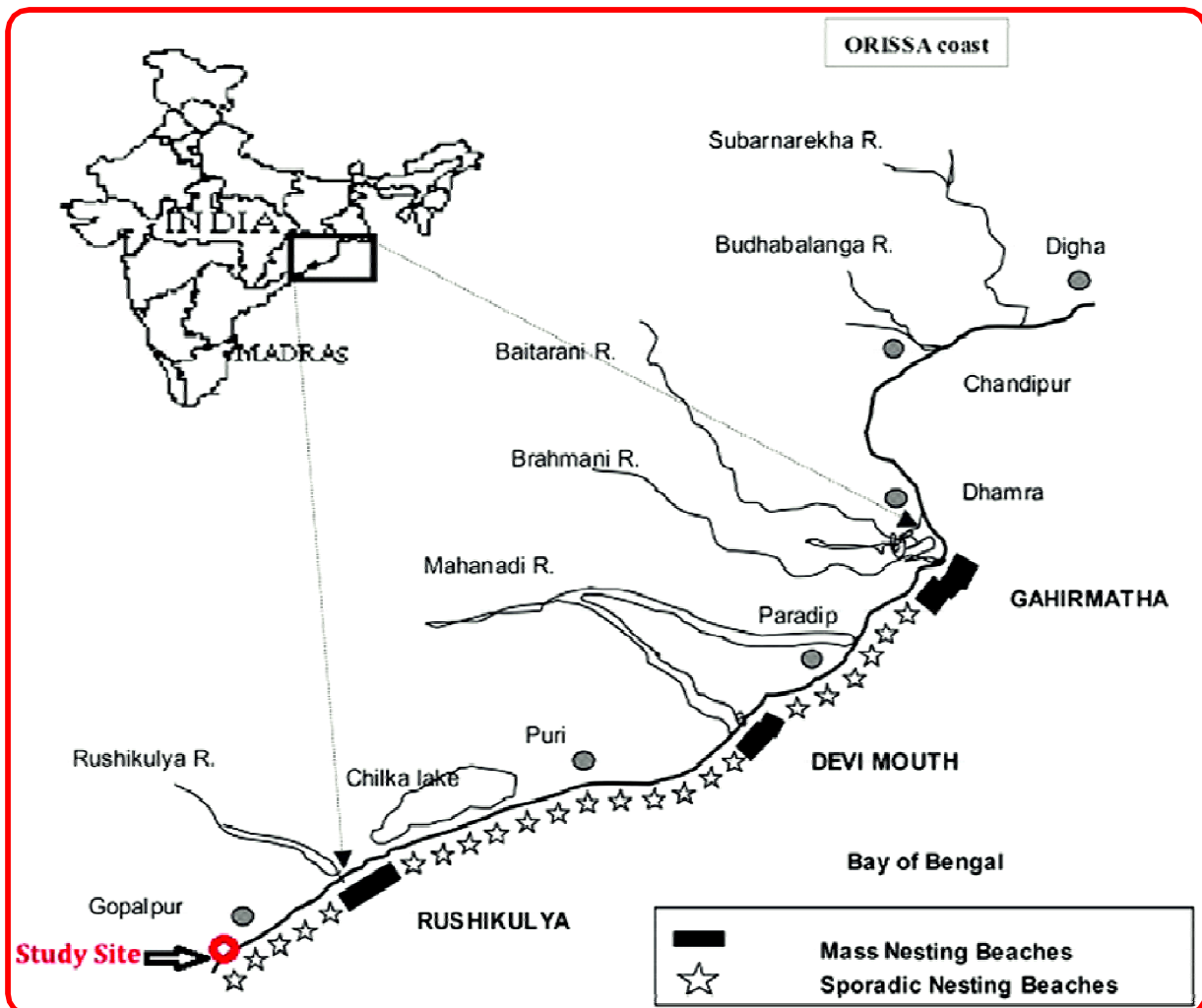

- ◆ Home to thousands of nests each year.
- ◆ Faces some conservation challenges due to coastal development and fishing activities.

The Olive Ridley turtles return to these very shores each year, following their inbuilt navigational instincts. They are believed to detect Earth's magnetic field and ocean currents, which guide them back to the beaches where they were born.

### **Odisha's Conservation Efforts: Protecting a Precious Heritage**

The Odisha government, along with various conservation groups, has been working tirelessly to protect and preserve the Olive Ridley turtles. Several key measures have been implemented:

#### **1. Fishing Ban During Breeding Season**

- To prevent accidental turtle deaths, the Odisha Forest Department enforces a strict ban on mechanized fishing near nesting sites from November to May.
- Turtles often get caught in fishing nets and drown, making this restriction crucial for their protection.

#### **2. Establishment of Protected Hatcheries**

- Authorities and conservation groups relocate vulnerable turtle eggs to artificial hatcheries, where they are protected from predators and environmental hazards.
- Once the eggs hatch, the baby turtles are carefully released into the sea.

#### **3. Community Involvement and Awareness**

- Local fishermen and villagers play a major role in turtle conservation. ? Volunteers are trained to assist in nest monitoring and protection.
- Government campaigns help raise awareness about the importance of marine biodiversity.

#### **4. Promotion of Turtle Excluder Devices (TEDs)**

- ◆ Turtle Excluder Devices (TEDs) are special nets that allow turtles to escape while catching fish.
- ◆ Fishermen are encouraged to use TEDs to reduce accidental deaths.

#### **5. Research and Monitoring Programs**

- ◆ Scientists and marine biologists conduct tagging and tracking programs to study the migration patterns of Olive Ridley turtles.
- ◆ This helps in understanding their movement and planning better conservation strategies.

#### **Threats to Olive Ridley Turtles**

Despite these conservation efforts, Olive Ridley turtles continue to face major threats:



## 1. Habitat Destruction and Coastal Erosion

- ◆ Rapid urbanization and coastal development are destroying natural nesting habitats.
- ◆ Rising sea levels are reducing available beach space for nesting.

## 2. Plastic and Marine Pollution

- ◆ Plastic waste in oceans chokes turtles and pollutes their habitat.
- ◆ Discarded fishing nets pose a huge risk as turtles often get entangled and drown.

## 3. Climate Change and Temperature Rise

- ◆ Increasing global temperatures affect egg incubation, leading to skewed sex ratios.
- ◆ More females are being born due to higher sand temperatures, which may impact future reproduction.

## 4. Illegal Poaching

Although banned, some regions still witness the illegal hunting of turtles for meat, eggs, and shell products.

## Why This Record-Breaking Nesting is Important

The arrival of 6.82 lakh Olive Ridley turtles in Odisha is a huge conservation success. This record-breaking event indicates that:

- ◆ Odisha's conservation policies are working effectively.
- ◆ The state is playing a crucial role in global marine biodiversity protection.
- ◆ It highlights the importance of sustainable coastal management.

This natural marvel also boosts eco-

tourism, attracting wildlife lovers, researchers, and photographers from around the world.

## Conclusion: A Symbol of Hope for Marine Conservation

The mass nesting of Olive Ridley turtles in Odisha is a sign of nature's resilience and a testament to effective conservation efforts. However, it also serves as a reminder of the challenges these magnificent creatures continue to face.

### To ensure their survival, we must focus on

- Stronger conservation laws and policies
- Sustainable fishing practices
- Reducing marine pollution
- Raising awareness about turtle protection

Odisha's success story should inspire global conservation efforts. By protecting these turtles, we are preserving a natural heritage that has existed for millions of years.

As the Olive Ridley hatchlings make their way into the vast ocean, they symbolize hope, resilience, and the urgent need for marine conservation. It's time we listen to the call of nature and protect our oceans for future generations.

## References

1. Odisha Forest Department Website – [<https://www.odishaforest.in>]
2. Wildlife Institute of India – [<https://wii.gov.in>]
3. National Wildlife Federation (NWF) – [<https://www.nwf.org>]
4. Pixabay Copyright free image

ଶୂକଳ

M.Sc, M. Phil (Zoology)  
Former Research Fellow at CIFA, Bhubaneswar

## ZOONOTIC IMPORTANCE OF CAT SCRATCH DISEASE IN HUMAN

<sup>1</sup>Akankhya Chakravarty

<sup>2</sup>Santwana Palai

<sup>3</sup>Kautuk Kumar Sardar

Cat scratch disease (CSD) is a bacterial disease which occurs most often in children under fifteen years of age. The bacteria can cause infection in heart valves leading to endocarditis. Every pet lover keeps their pet cat as their own child along with taking care of that cat very cautiously. CSD is a disease caused by *Bartonella* bacteria that can be transmitted from cats to humans, hence increasing its zoonotic importance. It is a facultative intracellular microbe that invades the RBCs. Even in humans, it targets the mature blood cells. The infection is usually mild but can lead to serious complications in the case of immune-compromised humans. Its transmission majorly occurs via cat fleas. blisters, rashes, bumps and papule like lesions are major clinical signs. It is diagnosed by history and clinical signs. In some cases, serological tests can be done for confirmatory diagnosis. As there is no specific treatment, only symptomatic treatment is preferred.

### Introduction

Cat is one of very adorable pet for human civilization and companion animal to the society. Cat scratches and bites can cause cat

scratch disease (CSD), a bacterial infection carried in cat saliva. Research suggests a cat may get these bacteria from fleas carrying the bacteria. Some evidence also suggests that these bacteria may spread directly to people by the bite of infected cat fleas, but this has not been proven. The bacteria is transmitted from an infected cat to a human through licking, by biting or scratching that breaks the skin barrier and gains entry into body circulation. Kittens younger than one year are more often seen being playful and scratching. Cat scratch disease (CSD) is a disease of zoonotic importance caused by *Bartonella* bacteria that can be transmitted from cats to humans. CSD in severe forms may be quite dangerous to the lives of infected humans. Veterinarians play a key role here to spread awareness among the pet owners and people in close contact with stray cats regarding the occurrence of CSD and steps that can be taken to prevent further transmission. With the increasing number of pets in households, there is an equal increase in the number of pet parents. Hence, it becomes essential to protect the health of both the pets and pet parents.



## CAT SCRATCH DISEASE

*A Hidden Menace*

Fig 1: Cat scratch

### Causative Agent

Cat scratch disease is a zoonotic disease that is spread from infected domesticated cats to humans in contact and is caused by a gram-negative bacterium called *Bartonellahenselae*. Earlier it was known by *Rochalimaeahenselae*. Domesticated and feral cats, mostly kittens less than one year age have fleas which carry the bartonella bacteria. The majority of the cats having the bacterial infection do not show any signs and symptoms hence it is difficult to diagnose. It is a facultative intracellular microbe that invades the RBCs. Even in humans, it targets the mature blood cells.

### Occurrence

Cat scratch fever is not very common, but anyone who is around a cat has a chance of getting infected. The infection is usually mild but can lead to serious complications in the case of immune-compromised humans. Pet parents must be very aware of their cat buddy's health because the most susceptible age group

of humans being affected is below 15 years. If you have children, then ensure utmost safety and keep your pets disease-free.

### Transmission

CSD is caused by a bacterium that is carried in the cat saliva. The bacteria is transmitted from an infected cat to a human through licking, by biting or scratching that breaks the skin barrier and gains entry into body circulation. CSD, also called cat scratch fever, is an uncommon bacterial infection that humans contract from a cat scratch or bite. Transmission occurs through the cat fleas.

- The fleas ingest blood containing Bartonella from an infected cat (usually kittens)
- The bacteria reproduce within the flea
- Flea sheds bacteria in its faeces
- When a cat scratches a person, the scratch can be contaminated with flea faeces. If the cat licks an open wound or

bites, it can also spread the bacteria

- There have been some evidence of direct flea bite also

### Signs and Symptoms

Infections involving spleen, liver, eye, brain, bones or heart is rarely seen. But the clinical signs can be visible as early as three days from cat bite or upto 10 days. The most common symptoms starts with red marks with become fluid filled called blisters followed by

- ◆ Rashes, bumps or cysts like papules observed under skin
- ◆ Sometimes, the bite area may be pus filled looking yellow
- ◆ The lymph nodes near the bite or scratch site is first observed to be swollen, which may be seen in distant lymph nodes also. Swelling may be seen after 1-2 weeks of the scratch which may get bigger like a

tennis ball. LNs are initially hot to feel that on a prolonged period gets filled with pus

- ◆ Muscle, bone or joint pain, low grade fever, loss of appetite and fatigue

Rarely, it may cause abdominal pain, sudden loss of sight, severe headache, epileptic fits and confusion.

### Diagnosis

CSD is difficult to diagnose because the symptoms are usually observed late and the affected person doesn't remember the history of bite or lick or scratch. Several methods are applied to diagnose CSD:

#### i. History taking:

The patient's exposure history to any infected cat is a primary diagnostic tool. Children playing with kittens, accidental scratches by the cats which does not leave any marks, cat licking on abrasions of patient are some the cases that often go unnoticed. The real-time history with facts is to be presented before the physician for accurate diagnosis and treatment of the disease.

#### ii. Clinical signs and symptoms

Visible red and abraded marks of the bite/scratch on body parts, nearby swollen lymph nodes, mild fever, blisters or papules

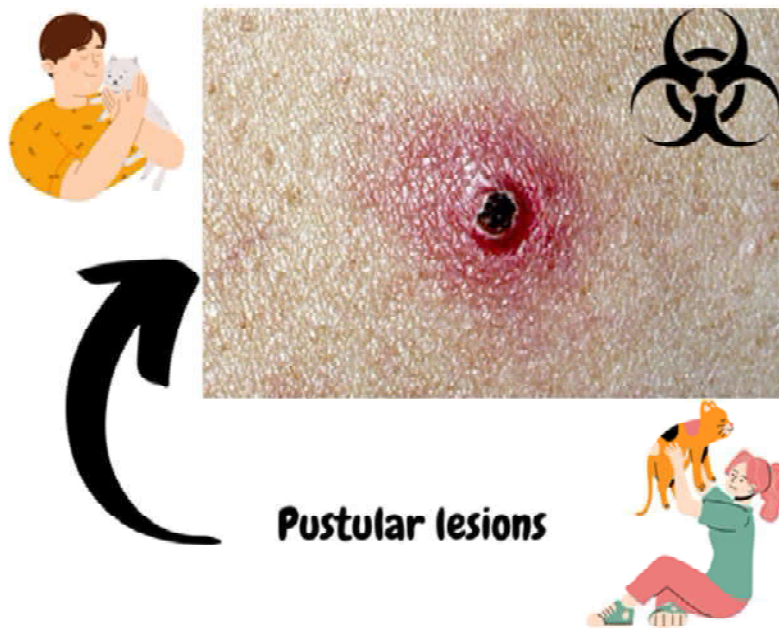

Fig 2: Blister formation due to cat scratch disease

on skin may give an indication regarding the disease.

### iii. Microscopic examination

Biopsy tissue samples of the swollen lymph nodes are collected, stained in gram stain and observed under microscope which indicates the presence of gram-negative curved rods. But this is not a confirmative method of diagnosis.

### iv. Laboratory tests

Indirect fluorescence antibody test or indirect fluorescence assay test can be done to detect the antibodies produced against the bacteria. This is generally not practiced.

### v. Polymerase chain reaction (PCR)

PCR detects the genetic constituency of the bacteria that shows specificity and sensitivity towards Bartonella which can be done on a patient's tissue.

Laboratory and microbiological tests, though not done frequently, serve as an excellent way to differentiate Bartonella infection from other bacterial infection. This becomes increasingly important in cat scratch disease since the patient usually tends to forget the history of scratch/bite.

### Treatment

- ◆ Although antibiotics are not preferred, but in case of pus-filled pustules and blisters, antibiotics is recommended.
- ◆ In case of excessive swelling, fluid from lymphnodes can be aspirated using a needle. But this is not recommended because it may lead to secondary bacterial infections and even fistulous drainage tracts.
- ◆ Antibiotics are recommended for immune-compromised patients (HIV/AIDs, Diabetes, etc.) because their immune systems are weak and not able to fight back the bacterial load may develop further complications. So, antibiotics like gentamicin, ciprofloxacin, doxycycline, azithromycin, rifampin are administered and found effective.

### Prevention and Control

- ◆ Till date, there is no vaccination available for Bartonella infection, but pet parents can join hands and take steps to overcome this challenge.
- ◆ Avoid involving yourself in any sorts of playful activities with your cats which annoys them and makes them aggressive.
- ◆ Keep small children away from aggressive and diseased cats.
- ◆ In case of any scratch, immediately wash the wound under running tap water first for 10 minutes. Then wash with soap water or antiseptic solution. Dry the wound area and bandage it to avoid any

further infections.

- ◆ Remember any bite or scratch history. Do not allow your pets to lick on any previously wounded or abraded surface.
- ◆ A person once infected with cat scratch disease develops immunity and becomes resistant against any further Bartonella infection.

## Conclusion

Cat is one of very adorable pet for human society. Every pet lover keeps their pet cat as their own child along with taking care of that cat very cautiously. Nothing to worry, if the person is living with HIV or is being treated for cancer, or have any other condition that might suppress your immune system. The pet lovers can keep the cat and there is no need to test or treat that healthy cat for *Bartonella*.

However, they should properly follow the vaccination schedule and deworming

schedule to keep their cat and themselves healthy. The pet parents should be aware of the significance of CSD. Since, most pet parents consider the cat scratch very lightly as a result; it may cause severe complications later. Some studies have found the *Bartonella* bacteria in the blood of up to 1 in 3 healthy cats, particularly kittens. So, by spreading awareness and encouraging the pet lovers to take proper preventive measures, the effect of cat scratch disease can also be reduced amongst pet owners in the society.

## References

1. <https://healthline.com/health/cat-scratch-disease#causes>
2. <https://my.clevelandclinic.org/health/diseases/23537-cat-scratch-fever>



College of Veterinary Science & Animal Husbandry,  
Odisha University of Agriculture & Technology,  
Bhubaneswar -751 003, Odisha

.....Continuing from Page No.-209

$$\begin{aligned}
 &= \lim_{h \rightarrow 0} \frac{1}{x} \frac{x}{h} \ln \left( 1 + \frac{h}{x} \right) \\
 &= \lim_{h \rightarrow 0} \frac{1}{x} \lim_{h \rightarrow 0} \frac{x}{h} \ln \left( 1 + \frac{h}{x} \right) \\
 &= \frac{1}{x} \lim_{h \rightarrow 0} \ln \left( 1 + \frac{h}{x} \right)^{\frac{x}{h}} = \frac{1}{x} \ln e \\
 &= \frac{1}{x}
 \end{aligned}$$

4. Evaluate  $\int \ln x \, dx$ .

$$\text{Sol: } = \int \ln x \, dx = \ln x \int dx - \int \left[ \left( \frac{d \ln x}{dx} \right) \int dx \right] dx$$

$$\begin{aligned}
 &= x \ln x - \int \left( \frac{1}{x} x \right) dx = x \ln x - \int dx \\
 &= x \ln x - x + c
 \end{aligned}$$

Logarithmic functions are used in real life to measure phenomena that span a large range of values, like earthquake intensity, sound intensity, pH level of a substance, radioactive decay, compound interest and astronomy.



PGT-Mathematics  
Ekalavya Model Residential School  
Pungar, Koraput, Odisha  
Pin-764036  
Mob.7735872724

## WIND ENERGY



Er. Mayadhar Swain

Wind has long been a symbol of movement and power. From propelling ancient sailing ships to grinding grain with windmills, humans have harnessed its energy for centuries. Wind is a form of solar energy. It is caused by the uneven heating of the atmosphere by the sun due to the irregularities of the earth's surface, and rotation of the earth. Wind flow patterns are modified by the earth's terrain, bodies of water, and vegetative cover. Today, wind energy stands as one of the fastest-growing sources of renewable power, a testament to its potential to drive the transition to a sustainable future.

### Wind Energy

The terms "wind energy" or "wind power" describe the process by which the wind is used to generate mechanical power or electricity. Wind turbines convert the kinetic energy of the wind into mechanical power. This flow, or kinetic energy of the wind, can be "harvested" with the help of modern wind turbines, and can be used for various applications including generation of electricity by coupling the turbine to a generator. This mechanical power can be used for specific tasks like grinding grain, saw milling, pumping water or electricity to power homes,

businesses, schools, etc.

### Wind Power Plant

The various components of a wind electric generating power plant are:

#### 1. Wind Turbines or rotor

Wind turbines, like aircraft propeller blades, get turned by the moving air and power an electric generator that supplies an electric current. Simply stated, a wind turbine is the opposite of a fan. Instead of using electricity to circulate wind in a fan, wind turbines use wind to make electricity. The wind turns the blades, which spin a shaft, which connects to a generator and makes electricity.

#### 2. Wind Mill Hub

The wind mill hub supports the rotor housing and bearing, it also houses control mechanism like changing blades pitch for safety device and allow the rotor to face the wind.

#### 3. Electrical Generator

It is coupled to the turbine and generates electricity.

#### 4. Supporting Structure

It is designed to withstand the wind force and the self load of the plant.

## Wind Turbine Types

Modern wind turbines fall into two basic groups;

Horizontal-axis turbine

Vertical-axis turbine

### Horizontal-axis Turbine

It is the most common type, with blades that rotate around a horizontal axis. It is the variety, like the traditional farm windmills used for pumping water. Most large modern wind turbines are horizontal-axis turbines. Horizontal-axis turbine components include:

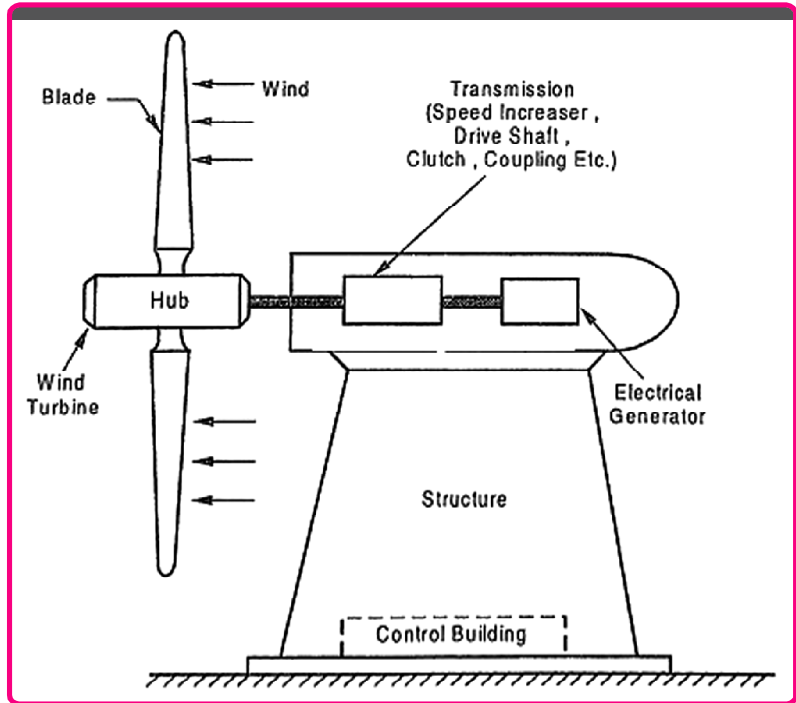

Wind power plant

(a) *Turbine Blades:*

Blades convert the energy in the wind to rotational shaft energy.

Turbine blades are made of high-density wood or glass-fiber and epoxy composites. The blades are slightly twisted from the outer tip to the root to reduce the tendency to stall. Modern rotor may be of the order of 100 m. Modern wind turbines have two or three blades.

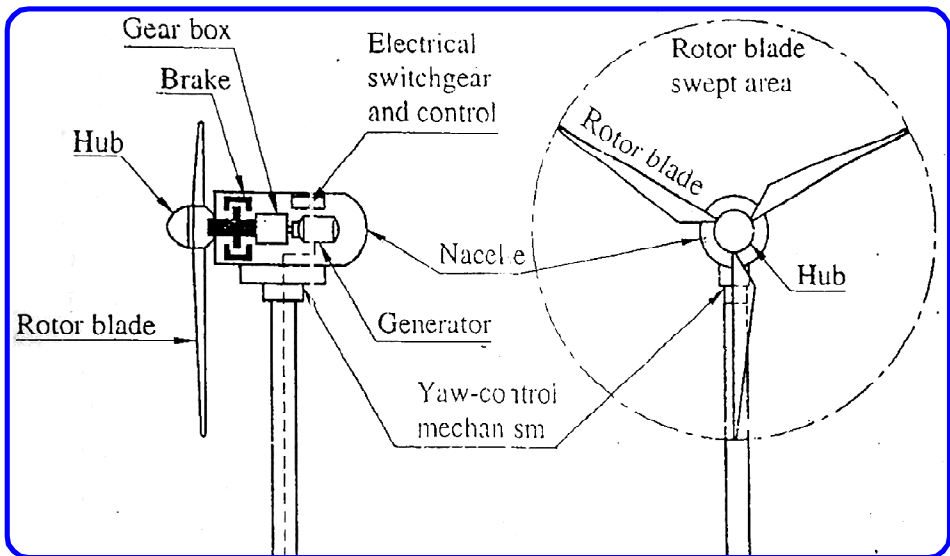

Horizontal-axis turbine

(c) *Nacelle:* The rotor is attached to nacelle, mounted at the top of tower. It contains rotor brakes, gearbox, generator and electrical switchgear. The generated electrical power is conducted to ground terminal through a cable.

(d) *Tower:* the tower supports the rotor and nacelle.

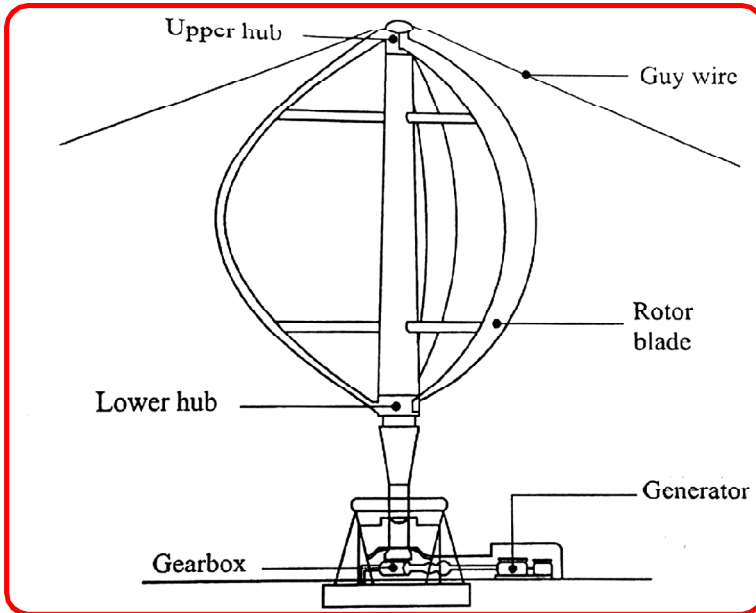

Vertical-axis turbine

of the rotor. Gearbox, generator, brakes, electrical switchgear and controls are housed within this structure.

### Turbine Power

The gross power extracted by the wind turbine is,

$$P = \frac{1}{2} \rho A V^3$$

Where,  $\rho$  = density of air

A = Area, through which the air flows

V = Velocity of wind =  $\pi d^2$

D = Diameter of turbine

### Vertical-axis Turbine

It is less common, with blades rotating around a vertical axis, useful in urban or low-wind areas. Its design is like the eggbeater-style Darrieus model, named after its French inventor. Gearbox, generator etc are located at the ground, thus eliminating the heavy nacelle at the top of the tower. Vertical-axis turbine components include:

(a) *Tower (or Rotor Shaft)*: The tower is a hollow vertical rotor shaft, which rotates freely about vertical axis between top and bottom bearings. It is installed above a support structure. The upper part of the tower is supported to guy ropes. The height of the tower of a large turbine is around 100 m.

(b) *Blades*: It has two or three thin aerofoil blades or rotor, which converts the energy in the wind to rotational shaft energy.

(c) *Support Structure*: Support structure is provided at the ground to support the weight

Theoretically, a fraction  $16 / 27 = 0.593$  (59.3%) of the power in the wind is recoverable. This is called Gilbert's limit or Betz coefficient.

### Wind Farm

It is a group of turbines installed on land or offshore to generate large-scale electricity.

### Characteristic of a Good Wind Power Plant Site

- ◆ High annual wind speed.
- ◆ A mountain gap.
- ◆ An open plain or an open shore line.
- ◆ There should not be any obstruction within a radius of 3 km.

### Advantages of Wind Energy

- ◆ Wind energy is a free source of energy.
- ◆ Renewable resource. It reduces reliance on imported fuels, enhancing national energy security.
- ◆ Wind energy is also a source of clean,

non-polluting, electricity. It produces no greenhouse gas emissions during operation.

- ◆ Low operation cost. Advances in technology and economies of scale have made wind energy one of the cheapest forms of electricity generation.
- ◆ Wind turbines can be located on land that is also used for grazing or even farming.
- ◆ Wind farms can range from small community projects to large-scale installations powering entire regions.

**Disadvantages of Wind Energy**

- ◆ Wind energy production depends on wind

availability, which can be variable and unpredictable.

- ◆ Wind farms require significant land area and can alter landscapes, raising concerns in some communities.
- ◆ Turbines can pose risks to birds and bats if not carefully sited.
- ◆ Remote wind farms require extensive transmission networks to deliver electricity to urban centres.
- ◆ The noise produced by the rotor blades.

**The Global Landscape of Wind Energy**

Countries around the world are leveraging wind energy to reduce their carbon footprints and ensure energy security. Notable

**Table-1**

Top 10 Countries by Operating Wind Farm Capacity in Megawatts (MW)			
Global Wind Power as on June 2024			
It includes wind farm phases 10 MW and greater.			
Global total operating capacity: 925,369 MW			
Rank	Country/Area	Operating Capacity (MW)	Percent of Global Total
1	China	395,681	42.76%
2	United States	144,957	15.66%
3	Germany	46,425	5.02%
4	India	35,422	3.83%
5	United Kingdom	30,826	3.33%
6	Spain	29,478	3.19%
7	Brazil	26,401	2.85%
8	France	24,800	2.68%
9	Canada	15,267	1.65%
10	Sweden	13,473	1.46%

examples include:

- **China:** The global leader in wind energy capacity, with massive onshore and offshore installations.
- **United States:** Home to extensive wind farms in states like Texas, Iowa, and Oklahoma, contributing significantly to the energy mix.
- **Denmark:** A pioneer in wind energy, generating nearly half of its electricity from wind power.
- **India:** With significant wind potential, particularly in Tamil Nadu and Gujarat, India ranks among the top wind energy producers globally.

### Floating Offshore Wind Turbines

Offshore wind energy is the generation of electricity through wind farms in bodies of water, usually at sea. There are higher wind speeds offshore than on land, so offshore farms generate more electricity. Unlike the typical use of the term “offshore” in the marine industry, offshore wind power includes inshore water areas such as lakes, ponds and sheltered coastal areas as well as deeper-water areas. Most offshore wind farms employ fixed-foundation wind turbines in relatively shallow water. Floating wind turbines for deeper waters are in an earlier phase of development and deployment.

Globally offshore wind energy is about two decades old history with the first offshore wind turbine in Denmark in 1991 which has been decommissioned in 2017. At the end of 2023, the installed capacity of offshore wind power plant in the world was 75 GW, out of

which 10.8 GW was commissioned in 2023. Further, capacity of 11 GW is in different stages of development. The 1.4 GW Homsea Project Two in the United Kingdom (UK) is now the world’s largest offshore wind power plant.

### The Role of Wind Energy in a Renewable Future

Wind energy is a cornerstone of global efforts to transition to renewable energy. Its scalability and cost-effectiveness make it a critical component of sustainable energy systems. By integrating wind energy with other renewables, governments and organizations can create robust and resilient energy networks.

- **Decentralized Power:** Small-scale wind installations empower local communities to generate their own electricity.
- **Grid Stability:** Paired with storage and smart grid technologies, wind energy enhances energy system reliability.
- **Decarbonization:** Expanding wind energy capacity is vital for meeting

Table-2

State	Installed capacity (MW)	Percentage
Gujarat	12368	
Tamil Nadu	11317.24	
Karnataka	6724.37	
Maharashtra	5216.38	
Rajasthan	5195.82	
Andhra Pradesh	4096.65	
Madhya Pradesh	2844.2	
Telangana	128.10	
Kerala	63.50	
Others	4.30	



climate goals and reducing reliance on fossil fuels.

### Indian Scenario in Wind Energy

In 2024, India reached 47.2 GW of wind energy capacity which is 10.5% of total renewable installed capacity. India plans to contract more than 100 GW of wind by 2030. Current installed capacity of different states is given in the table-2.

### Conclusion

Wind energy harnesses one of nature's

most powerful forces to deliver clean and sustainable power. As technology continues to evolve and adoption expands, wind energy will remain a driving force in the global shift toward a renewable energy future. In the next chapter, we will explore the emerging role of bioenergy and its potential to revolutionize the energy landscape.



Editor, Science Horizon  
70, Laxmi Vihar Phase 1, Bhubaneswar – 751018  
Phone: 9438693724

.....*Continuing from Page No.-220*

warring states period bamboo slips was used as early as the late Shang period (from about 1250 BC).

Bamboo or wooden strips were used as the standard writing material during the early Han dynasty, and excavated examples have been found in abundance. Subsequently, paper began to displace bamboo and wooden strips from main-stream uses, and by the fourth Century AD, bamboo slips had been largely abandoned as a medium for writing in China.

Bamboo pulps are mainly produced in China, Myanmar, Thailand, and India, and are used in printing and writing- papers. Several paper industries are surviving on bamboo forests. Ballarpur (Chandrapur, Maharashtra) paper mills use bamboo for paper production. The most common bamboo species used for paper production are *Dendrocalamus asper* and *Bambusa blumeana*. It is also possible to make

dissolving-pulp from bamboos. The average fiber length is similar to hardwoods, but the properties of bamboo pulp are closure to softwood pulps due to it having a very broad fiber length distribution. With the help of molecular tools, it is now possible to distinguish the superior fiber-Yielding species/varieties even at juvenile stages of their growth, which can help in un-adulterated merchandise production.

In central India, there are regular bamboo working circles in forest areas of Maharashtra, Madhyapradesh, Odisha and Chhattisgarh. Most of the bamboo is harvested for papermaking. Bamboo is cut after three years of its germination. No cutting is done during rainy season (July-September); broken and malformed Culms are harvested first.



Retired Principal & LM, OES  
Plot No. 506, G.A. Colony, Bharatpur  
Bhubaneswar, 751029  
Mob. 9437467474

12

## MAHENDRAGIRI: RATIONALE FOR A BIOSPHERE RESERVE



**Dr. Bijay Ketan Patnaik**

Located around the south-eastern boundary of Odisha in Gajapati district, the Mahendragiri hill complex is the pride of the Eastern Ghat that runs parallel to the Bay of Bengal. Mahendragiri is considered one of Odisha's most biodiverse landscapes. Mahendragiri peak is about 1501 meters above mean sea level. This is the second highest peak of Odisha after Deomali hill, situated in Koraput district. As per bio geographic classification of Rodgers & Panwar (1988), Mahendragiri falls under the Deccan Peninsular Bio geographic region. According to Champian and Seth (1968) classification, the flora of Mahendragiri can be divided into dry deciduous forest (below 700 m- foothills), tropical moist deciduous forest (700-1000 m), which is predominant in larger areas of the hill range. The upper valley lies in tropical semi-evergreen forest (1000-1200 m) mixed with shola forest above 1200 meters and beyond in small pockets, while grasslands show on the plateau of hill ranges beyond 1200 meters. According to species classification, the flora of Mahendragiri hill range can be classified as sal forest, mixed forest, shola forests, grassland and scrub forests. Sal is the main species in both dry

and moist deciduous forests.

Between 1973 and 1980, botanist Brahmam of the then Regional Research Laboratory of Odisha elaborately studied Mahendragiri's flora and identified 642 plant species. Recently, the Odisha State Biodiversity Board identified 1370 plant species including several (60) threatened and 5 endemic species. As one of Odisha's medicinal plant hotspots, Mahendragiri boasts wild edible plants, medicinal plants, tubers, mushrooms, orchids, and ferns. As per the IUCN red data booklist, 41 species of threatened medicinal plants were found in Odisha as part of the Conservation Assessment & Management Prioritization workshop jointly organized by FRLHT (Foundation for the revitalization of local health traditions, Bengaluru) and RPRC (Regional Plant Resource Center, Bhubaneswar). Mahendragiri contains 20 of these species. Similarly, out of 32 plant species in the country, identified by the National Medicinal Plants Board requiring conservation and management, 18 species are present in the Mahendragiri ecosystem. The hill range is also home to 44 orchid species—some endemic. Floristically, the hill range represents

40% of reported flora of Odisha. Interestingly these ranges harbour both Himalayan and South Indian Peninsular species; a pointer to species migrating from the lower Himalayas to the South Indian Peninsula or vice versa through these ranges. That is the reason this hill range has attracted the attention of several celebrated taxonomists in the past. This spectacular but ecologically fragile high-altitude ecosystem warrants immediate attention for preservation and conservation.

Mahendragiri's diversified vegetation also sustains rich faunal groups: mammals, birds, reptiles, amphibians, butterflies etc. Of the total 545 animal species recorded, 13 are considered threatened of which two are endemic. Mahendragiri is well-known for its Indian elephants. The rulers of the erstwhile royal dynasty were addressed as 'Gajapati' (Gaja means elephant) now the district is called Gajapati. Due to high human activity, wildlife wealth is declining.

Mahendragiri and its surrounding localities are inhabited largely by tribal communities. The aboriginal primitive tribes consist of langiasaura, sudhha and bhimasaura, kondh, Pulian, Dora, Gadaba and Jatagu tribes. Mahendragiri's bio-resources sustain a part of livelihood of tribal communities. Collection of minor forest produce such as fuel wood, sal and siali leaves, sal seeds, mahua flowers, sabai grass, hill brooms and medicinal herbs and shrubs provides them with a constant source of income throughout the year. Since most hamlets are on hill slopes, shifting cultivation has become a way of life. They produce millets, legumes, fruits like pine apple,

orange and lemon, vegetables, cereals like Suan, Rice and Maize, spices like turmeric etc.

Its mythological, historically ancient and archaeological features, along with its associated cultural significance, make Mahendragiri a heritage mountain in Odisha. It's three hoary monuments, Kunti, Judhisthir, and Bhima temple, exhibit archaeological marvels and are protected as National Monuments since 1964. Recently, the Indian Government consecrated these sites under the Ramayan circuit. These temples are believed to have been built between the 4th and 10th centuries CE. In light of the rapid depletion of its natural resources and deterioration of ancient archaeological monuments of epic fame due to significant stress and strain, it is imperative to declare Mahendragiri as Odisha's second Biosphere Reserve, in order to protect and conserve this fragile ecosystem.

In 1986, the Union Environment & Forest ministry advised the Odisha government to declare Mahendragiri as biodiversity hotspot. The Wildlife Institute of India, Dehradun, during 1988, in their report recommended setting up of a sanctuary of 50 sq km in Mahendragiri, based on their phyto-geographic affinities to the north, north-eastern and south-eastern part of the country. For its implementation, the Union Ministry of Environment & Forest in its recommendation report advised the Odisha Government to increase the coverage area by creating a Biosphere Reserve encompassing the entire hill range-with the sanctuary at its heart. But subsequently, a mini Biosphere Reserve was established at Kainpur in the foothills in a

minuscule area of 21.85 sq km.

Biological Reserves focus on ecological, economic, and human development while protecting the environment and providing sustainable development for local residents, who are integral parts of the Reserve. A Biosphere Reserve is a three-tier system, consisting of the central core zone with concentration of indigenous species both flora and fauna, the peripheral zone where man and animal co-exist and a transitional zone where all kinds of sustainable development activities can be taken up. This is a UNESCO concept originating from the Man and Biosphere program of 1971. Under aegis of this program, Similipal forest was declared as the first Biosphere Reserve of Odisha in 1994. Since that time, many nature loving organizations, including Odisha Environment Society have been constantly pursuing with the state government and union government to declare Mahendragiri hill range as the second Biosphere Reserve based on its ecological, historical, mythological, anthropological and archaeological importance. Following the recommendation of Union government, the State government constituted an expert committee to study the feasibility of the project. The Odisha Remote Sensing Application Centre conducted a satellite survey of the hill ranges. Based on the survey, it proposed creation of a Biosphere Reserve of 4715.28 sq km-42.54 sq km of core area, 1577.02 sq km of peripheral or buffer area and 3095.72 sq. km of transitional area.

The State Government proposal was considered by the Man and Biosphere

Committee of the Union government in April 2007. Scientists/researchers of Odisha State Biodiversity Board were entrusted with an in-depth study and research on the uniqueness of flora and fauna, aboriginal inhabitants and archaeological monuments based on the committee's recommendations. The scientists did a commendable job and compiled the data in a book, titled "Magical Biodiversity of Mahendragiri Hills". Under the Biodiversity Act 2002, the State Government declared Mahendragiri a Biodiversity Heritage Site based on the report submitted by the board. The initial hurdle was overcome. But it wasn't enough. This was far from what should have naturally followed. Even after 17 years, Mahendragiri, which boasts a rich biodiverse ecosystem, has not been granted the status of a Biosphere Reserve.

In the meantime, as the world grapples with global warming and climate change, with polar glacial melting, permafrost thawing, and the amazing news of some parts of the Amazon river ready to be dredged up for navigation, any tiny nature conservation in remote parts of the earth is most heartening. One fervently hopes Mahendragiri gets its due as a Biosphere Reserve which is long overdue. All it takes is for the Odisha government to act quickly as per the union environment and forest ministry's directives.

The ball is now in the court of Government of Odisha to take the issue forward.

ଶୂର

Former Chief Editor, Bigyan Diganta  
57, Jagamohan Nagar, Jagamara, Bhubaneswar  
Mob: 9437000904

## RECENT NEWS ON SCIENCE & TECHNOLOGY

### Scientists Uncover a Massive Gravity Hole

Scientists have discovered a massive gravity anomaly beneath the Indian Ocean, revealing a hidden force deep within the Earth that could reshape our understanding of the planet's interior. It is a massive gravitational anomaly where the ocean surface dips an astonishing 106 meters lower than surrounding areas. Known as the Indian Ocean Geoid Low (IOGL), this region experiences weaker gravitational forces than anywhere else on Earth, and until now, its origins remained a mystery.

In a recent study published in *Geophysical Research Letters*, Prof. Attreyee Ghosh, an Assistant Professor at the Centre for Earth Sciences, Indian Institute

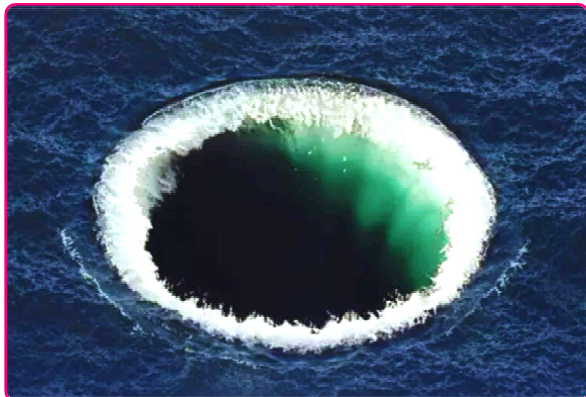

of Science, Bangalore and her colleagues, along with researchers from the GFZ German Research Centre for Geosciences, investigated the missing mass causing the geoid low. The research suggests that the anomaly may be linked to mantle convection processes dating back over 140 million years. They discovered that the gravity low is linked to anomalous mantle activity—specifically, the presence of lighter, hotter material stretching from a depth of 300 km to nearly 900 km beneath the Indian Ocean.

### Astronomers Discover 128 New Moons of Saturn

On 11 March 2025, the International Astronomical Union (IAU) recognized 128 new moons in orbit around Saturn, discovered by astronomers from Taiwan, Canada, the United States and France. Saturn's new grand total of 274 moons is almost twice as many as all the rest of the moons in our solar system combined. So, the planet has clearly earned the title of “moon king.”

The moons are “irregular,” approximately potato-shaped and only a few miles across. They orbit at distances between 6.5 million



(An artistic rendering of Saturn and a few of its many moons)

and 18 million miles from the planet. In contrast, Saturn's rings extend only 175,000 miles, and its major moons, like Titan and Enceladus, orbit within 2 million miles.

The discoveries were made in 2023 using the Canada-France-Hawaii Telescope at Mauna Kea. The research team observed Saturn's surroundings and tracked previously unknown moons' movements.

## Nuclear Battery

In the world of batteries, duration is king. Whether nestled in the smallest wearable or providing back-up power for the electric grid, a battery that provides reliable energy for longer will always outlast the competition-figuratively and literally. The U.S. led the way in nuclear battery innovation over the past 70 years and even developed the first battery that ran on nuclear radiation in the 1950s. But in the 21st century, China has become the undisputed leader of nuclear batteries, which make it possible to power endeavors for decades without needing to recharge. In early 2024, the Chinese company Betavolt revealed a coin-sized

nuclear battery named BV100 that uses Nickel-63 as its radioactive source, yielding an estimated 50-year lifespan. The betavoltaic battery's long life-coupled with its ability to operate in extreme conditions-makes it perfectly suited for planetary rovers, deep sea sensors, and even pacemakers.

## AI Humanoids to Explore Moon and Mars

Muks Robotics, a Pune-based company, is developing cutting-edge robots designed for planetary exploration, specifically targeting missions to the Moon and Mars. It is working on advanced robots like Spaceo Prime, a conscious bipedal humanoid robot, and Robo Prime for Mars missions. These robots are engineered to collect and analyze planetary data on-site, providing real-time inferences and critical data directly to Earth. Spaceo



Prime is equipped with the capability to aid in the construction of colonies on Mars and beyond by leveraging its advanced AI technology. Robo Prime, on the other hand, is specifically designed for the Martian terrain, focusing on tasks that are currently beyond human capabilities.

Compiled by  
EDITOR

## **GUIDELINES FOR CONTRIBUTING ARTICLES FOR THE MAGAZINE**

1. "SCIENCE HORIZON" aims at developing the scientific outlook of students as well as the general people and seeks to give them information on scientific developments. It is published as a monthly magazine.
2. The authors desirous of writing and contributing articles to the magazine should first assimilate the ideas of the theme and present it in simple language and popular style.
3. The authors are requested to send their articles by typing (**in MS Word**) to avoid errors in reading handwritten article and send it through e-mail given below.
4. The authors are requested to write clearly on one side of A4 size paper. The relevant pictures in 4cm X 6 cm size are welcome. **Photo copies of manuscripts are not accepted for consideration.**
5. Each article will be ordinarily of two to three printed pages in A4 size papers.
6. The article shall be profusely illustrated with pictures.
7. At the end of the article the author should give the references and suggestions for further reading.
8. The reference of books, journals, sources, ideas and essential points collected by the writer should be mentioned in the bibliography. This will enhance the quality and fidelity of the writing and give the reader an opportunity for making further studies.
9. Matter translated from other languages and illustrations should indicate the original sources otherwise those would not be accepted. The articles which are not published, can not be returned to the authors.
10. As far as practicable the articles should be based on **contemporary science** and must be easily comprehensible to students at the secondary level.
11. The writers should present difficult concepts of science through stories of everyday life, heart-rendering songs, pictures, satirical cartoons or attractive dramas.
12. All units in the articles should be given in the metric system.
13. The title of the article should be brief and attractive. Moreover, subtitles may be given in long articles. The writings should be coherent and cohesive.
14. There should not be repetition of specific words. While ensuring the contemporary spirit of the writing, it should reflect some valuable lesson for the society. It is also necessary to avoid mistakes in spelling, language use and factual details.
15. The Editor & the Editorial Board of "Science Horizon", Secretary of the Academy or Odisha Bigyan Academy shall not be responsible for the views of the authors.
16. The authors are requested to provide their **bank details (Name of the Account Holder, Bank & Branch Name, Account Number and IFS Code)** for payment of honorarium.

### **Address for sending the articles:**

The Secretary,  
Odisha Bigyan Academy,  
Plot No. B/2, Saheed Nagar,  
Bhubaneswar - 751 007  
Telephone - 0674-2543468  
**E-Mail - cesh.oba1@gmail.com**

website : [www.odishabigyanacademy.nic.in](http://www.odishabigyanacademy.nic.in)  
e-mail: [odishabigyanacademy1@gmail.com](mailto:odishabigyanacademy1@gmail.com)

Price : 10.00



**FELICITATION & AWARD INVESTITURE CEREMONY-2023**  
on 28<sup>th</sup> March, 2025



**SCIENCE TRAINING PROGRAMME**  
Organised by  
**ODISHA BIGYAN ACADEMY on 1<sup>st</sup> April, 2025**